

Solid State Relays

G3NB

SSR with 40-A output at a reasonable price.
Switches 9 A without a heat sink.

- Zero cross function enables less noise operation.
- Built-in varistor effectively absorbs external surges. (-UTU models)
- Operation indicator enables monitoring operation.
- Protective cover for greater safety. (-UTU models)
- Standard models certified by UL and CSA and -UTU models by TÜV.



Model Number Structure

Model Number Legend

G3NB-□□□-□
1 2 3 4 5

1. Basic Model Name

G3NB: Solid State Relay

2. Rated Load Power Supply Voltage

2: 200 VAC

3. Rated Load Current

40: 40 A

4. Terminal Type

B: Screw terminals

5. Certification

Blank: Standard models (UL and CSA certification)

UTU: Certified by UL, CSA, and TÜV

Ordering Information

List of Models

Isolation	Zero cross function	Indicator	Applicable output load (See note 2.)	Rated input voltage	Model
Photocoupler	Yes	Yes	40 A at 110 to 220 VAC	5 to 24 VDC	G3NB-240B 5 to 24 VDC
					G3NB-240B-UTU 5 to 24 VDC

Note: 1. The standard models are certified by UL and CSA. To order a CE-conformed model, add "-UTU" to the model number.

2. The applicable output load depends on the ambient temperature. Refer to "Load Current vs. Ambient Temperature" in Engineering Data.

Accessories (Order Separately)

One-touch Mounting Plates

Model
R99-12 FOR G3NA

Heat Sinks

Slim Models Enabling DIN-track Mounting

Model	Applicable SSR
Y92B-N150	G3NB

Low-cost Models

Model	Applicable SSR
Y92B-A150N	G3NB

Specifications

■ Ratings

Input (at an Ambient Temperature of 25°C)

Model	Rated voltage	Operating voltage	Rated input current	Voltage level	
				Operation voltage	Release voltage
G3NB-240B	5 to 24 VDC	4 to 32 VDC	7 mA max.	4 VDC max.	1 VDC min.
G3NB-240B-UTU	5 to 24 VDC	4 to 32 VDC	7 mA max.	4 VDC max.	1 VDC min.

Output

Model	Applicable load				
	Rated load voltage	Load voltage range	Load current (See note 1.)		Inrush current
			With heat sink (See note 2.)	Without heat sink	
G3NB-240B	110 to 220 VAC	77 to 286 VAC	0.1 to 40 A (at 40°C)	0.1 to 9 A (at 40°C)	410 A (60 Hz, 1 cycle)
G3NB-240B-UTU	110 to 220 VAC	77 to 286 VAC	0.1 to 40 A (at 40°C)	0.1 to 9 A (at 40°C)	410 A (60 Hz, 1 cycle)

Note: 1. The load current varies depending on the ambient temperature. Refer to *Load Current vs. Ambient Temperature* under *Engineering Data*.
2. When an OMRON Heat Sink (refer to *Options*) or a heat sink of the specified size is used.

■ Characteristics

Item	G3NB-240B	G3NB-240B-UTU
Operate time	1/2 of load power source cycle + 1 ms max.	
Release time	1/2 of load power source cycle + 1 ms max.	
Output ON voltage drop	1.6 V (RMS) max.	
Leakage	5 mA max. (at 100 VAC)	
Insulation resistance	100 MΩ min. (at 500 VDC)	
Dielectric strength	2,500 VAC, 50/60 Hz for 1 min	
Vibration resistance	Destruction: 10 to 55 to 10 Hz, 0.75-mm single amplitude (1.5-mm double amplitude)	
Shock resistance	Destruction: 1,000 m/s ²	
Ambient temperature	Operating: -30 to 80°C (with no icing or condensation) Storage: -30 to 100°C (with no icing or condensation)	
Ambient humidity	Operating: 45% to 85%	
Weight	Approx. 90 g	

Engineering Data

Load Current vs. Ambient Temperature

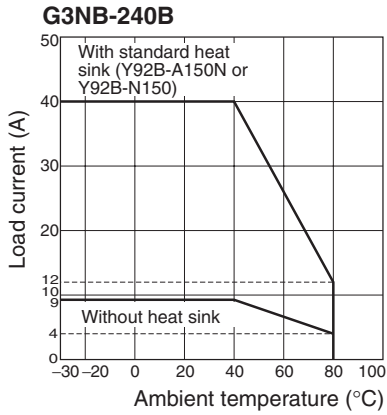

One Cycle Surge Current

The values shown by the solid line are for non-repetitive inrush currents. Keep the inrush current below the values shown by the dotted line if it occurs repetitively.

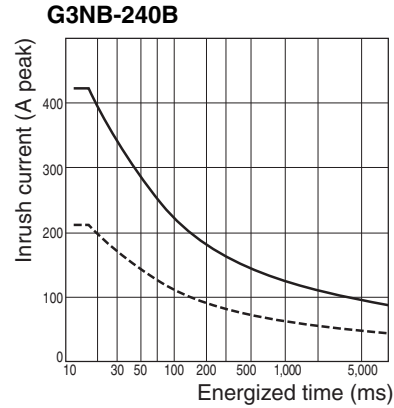

Thermal Resistance Rth of Heat Sinks (Examples)

Model	Rth (°C/W)
Y92B-N150	1.38
Y92B-A150N	1.37

Note: When using a commercially available heat sink, use one with a thermal resistance equal to or less than that of the OMRON Heat Sink.

Dimensions

Relays

Note: All units are in millimeters unless otherwise indicated.

G3NB-240B,
G3NB-240B-UTU

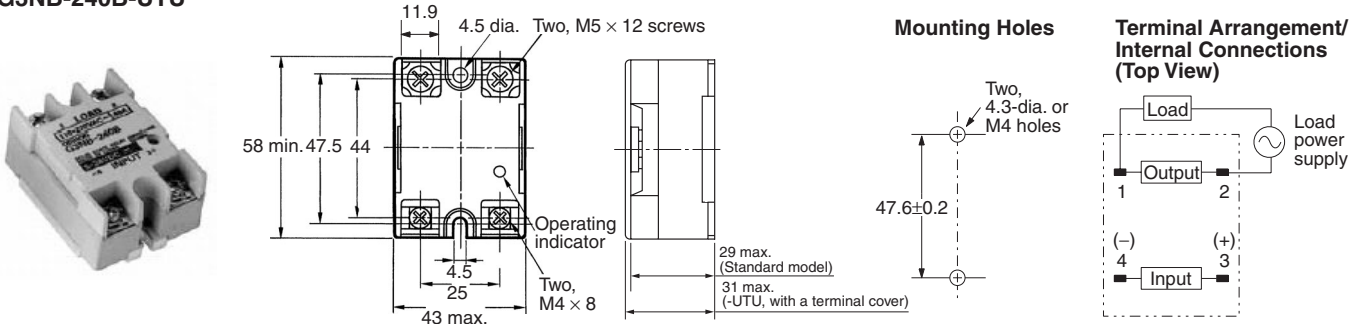

Options (Order Separately)

One-touch Mounting Plate

The One-touch Mounting Plate is used to mount the G3NB to a DIN Track.

R99-12 FOR G3NA

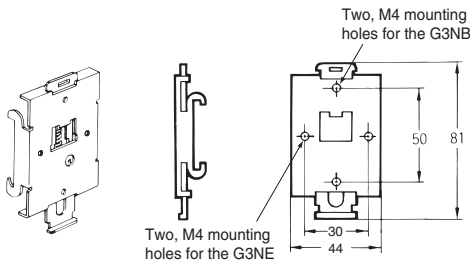

To mount the Relay to DIN Track, first mount it to the One-touch Mounting Plate and then attach it to the DIN Track as shown in the diagram.

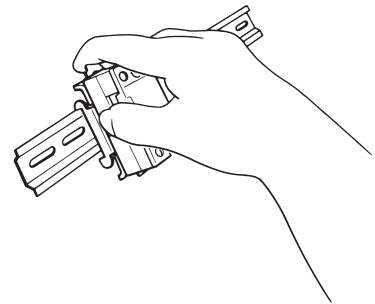

To remove the Relay from the DIN Track, pull down on the tab with a screwdriver in the direction of the arrow.

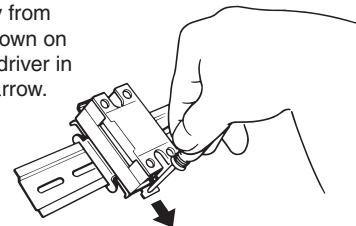

- When a Relay is mounted to DIN Track, use it within the rating for a Relay without a heat sink.
- Use the following DIN Tracks: PFP-100N or PFP-100N2.

Heat Sinks

Y92B-N150 Heat Sink (for the G3NB-240B)

For surface mounting, a 30% derating of the load current is required (from the *Load Current vs. Ambient Temperature* graphs).

The orientation indicated by the external dimensions is not the correct mounting orientation. When opening mounting holes, refer to the mounting hole dimensions.

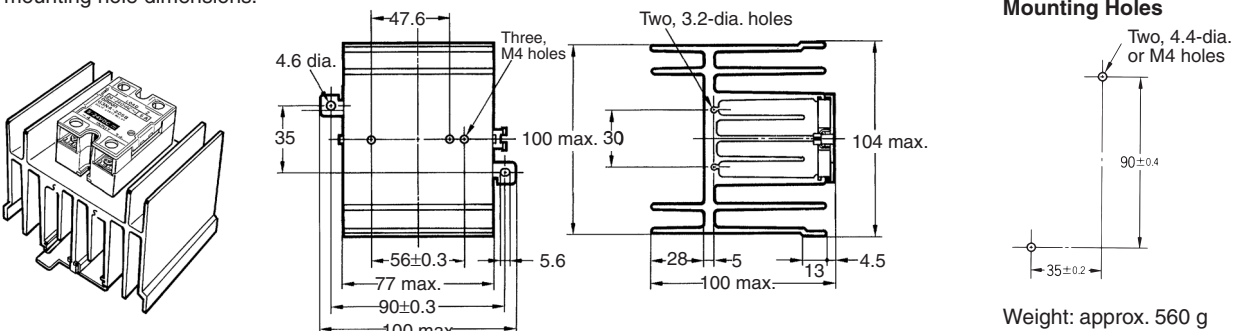

**Y92B-A150N Heat Sink
(for the G3NB-240B)**

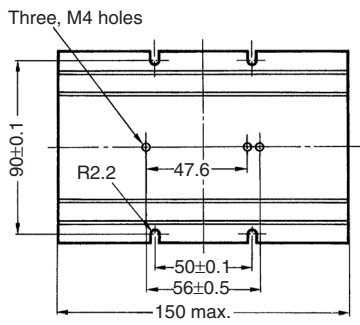

Weight: approx. 310 g

**Mounting Holes
Y92B-A150**

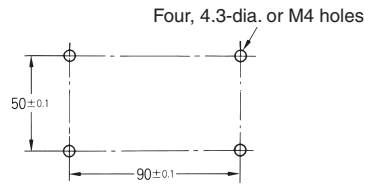

For surface mounting, a 30% derating of the load current is required (from the *Load Current vs. Ambient Temperature* graphs). The orientation indicated by the external dimensions is not the correct mounting orientation. When opening mounting holes, refer to the mounting hole dimensions.

Safety Precautions

⚠ CAUTION

Installation and Installation Environment

- Be sure to conduct wiring with the power supply turned OFF, and always attach the terminal cover after completing wiring. Touching the terminals when they are charged may occasionally result in minor electric shock.
- The G3NB may rupture if a short-circuit is applied to it. To protect against short-circuit accidents, install a protective device, such as a quick-burning fuse, on the power supply line.



Maintenance

- The internal snubber circuit is charged and may occasionally cause minor electric shock. Do not touch the G3NB's main circuit terminals immediately after the power is turned OFF.
- The G3NB and heat sink will be hot and may occasionally cause minor burns. Do not touch the G3NB or the heat sink either while the power supply is ON, or immediately after the power is turned OFF.



■ Important Notice

1. The standard G3NB models are not equipped with a varistor as a surge absorber.

Therefore, the endurance for impulse surge and noise of the G3NB is weaker than that of the G3NA.

If you use SSR in environments subject to surge and noise, we recommend using the G3NA-240B or G3NB-240B-UTU.

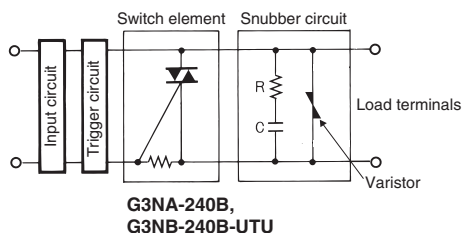
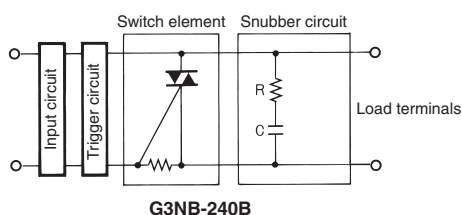

2. The standard G3NB models are not equipped a terminal cover.

If you need a terminal cover, please use the G3NA-240B or G3NA-240B-UTU.

3. The reliability of the output device of the G3NA-240B is better than that of the G3NB.

The output device of the G3NB is different from that of the G3NA-240B.

If you need higher reliability, we recommend using the G3NA-240B.

	Load current of SSR (at 40°C) with standard heat sink	Rated current of output device
G3NB	40 A max.	40 A max.
G3NA-240B	40 A max.	50 A max.

■ Precautions for Safe Use

Transport

Do not transport the G3NB under the following conditions. Failure, malfunction, or deterioration of performance characteristics may occur.

- Conditions under which the G3NB will be exposed to water or oil
- High temperatures or high humidity
- Without proper packing
- Conditions under which rapid temperature changes may occur, resulting in the formation of condensation.

Use and Storage

Do not use or store the G3NB in the following locations. Doing so may result in damage, malfunction, or deterioration of performance characteristics.

- Do not use or store in locations subject to rain or water drops.
- Do not use or store in locations subject to exposure to water, oil, or chemicals.
- Do not use or store in locations subject to high temperatures or high humidity.
- Do not store in locations subject to ambient temperatures outside the range -30 to 100°C.
- Do not use in locations subject to relative humidity outside the range 45% to 85%.
- Do not use in locations subject to condensation as the result of severe changes in temperature.
- Do not use or store in locations subject to corrosive or flammable gases.
- Do not use or store in locations subject to dust (especially iron dust) or salts or in locations subject to salt damage.
- Do not use or store in locations subject to direct sunlight.
- Do not use or store in locations subject to shock or vibration.

Use and Handling

- Do not obstruct the airflow to the G3NB or heat sink. Heat generated from an G3NB error may occasionally cause the output element to short, or cause fire damage.
- Do not mount the G3NB when your hands are oily or dirty, e.g., with metal powder. These may cause G3NB failure.

Use and Installation

- Mount the G3NB in the specified orientation. If the G3NB is mounted in any other orientation, abnormal heat generation may cause output elements to short or may cause burning.
- Be sure to prevent the ambient temperature from rising due to the heat radiation of the G3NB. If the G3NB is mounted inside a panel, install a fan so that the interior of the panel is fully ventilated.
- When mounting the G3NB to a heat sink or radiator, apply a thin layer of Toshiba Silicone's YG6260 or Sinetsu Silicone's G746, or a similar product, to the mounting surfaces prior to mounting.
- If a material with high thermal resistance, such as wood, is used, heat generated by the G3NB may occasionally cause fire or burning. When installing the G3NB directly into a control panel so that the panel can be used as a heat sink, use a panel material with low thermal resistance, such as aluminum or steel.
- Use the specified heat sink or one with equivalent or better characteristics. Failure to do so may result in short-circuiting or burning of the output elements due to abnormal heating.
- Tighten the G3NB screws securely. Tightening torque: 0.78 to 0.98 N-m
- Tighten the heat sink screws securely. Tightening torque: 0.98 to 1.47 N-m

Use and Wiring

- Abnormal heat generated by wires may occasionally result in burning damage or melting of the wire sheath, leading to electric shock. Use wires suitable for the load current.
- Do not use any wires with damaged sheaths. These may cause electric shock or leakage.
- Do not place wires in the same conduit or duct as high-voltage lines. Induction may cause malfunction or damage.
- Use wires of an appropriate length, otherwise improper operation, malfunction and burning may result due to induction.
- Heat generated by a terminal error may occasionally result in fire damage. Do not operate if the screws on the terminal are loose.

Tightening Torque

Screw size	Tightening torque
M4	1.2 N·m
M5	2.0 N·m

- Abnormal heat generated by terminals may occasionally result in fire damage. When tightening terminal screws, be sure that no non-conductive foreign matter is caught in screw.
- Turn OFF the power before doing any wiring work. Failure to do so may cause electric shock.

Use

- Only use the G3NB with loads that are within the rated values. Using the G3NB with loads outside the rated values may result in malfunction, damage, or burning.
- Use a power supply within the rated frequency range. Using a power supply outside the rated frequency range may result in malfunction, damage, or burning.
- For G3NB Relays of 40 A or higher, use crimp terminals of an appropriate size for the wire diameter for M5 terminals. Failure to do so may occasionally result in burning damage or melting of the wire sheath, leading to electric shock.
- G3NB malfunction or fire damage may occasionally occur. Do not apply excessive voltage or current to the G3NB terminals.

Precautions for Correct Use

- Do not drop the G3NB or subject it to strong vibration during transport or installation, or this may adversely affect the characteristics or cause improper operation or malfunction.
- Do not transport the G3NB in an unpackaged condition, or this may cause damage or malfunction.
- Do not allow solvents, such as thinner or gasoline, to come into contact with any resin parts on the G3NB, or this may cause the markings on the G3NB to rub off.
- Do not allow oil to come into contact with the cover of the terminal block on the G3NB, or this may cause the cover to turn whitish or crack.

Mounting Orientation

When mounting the G3NB to a flat surface, refer to *Load Current vs. Ambient Temperature* to reduce the load current by 30%.

Output Noise Surges for AC Switching SSRs

Connect a surge absorber (varistor) to both ends of the SSR load, and in parallel with the load. Use varistors with the following elements.

Line Voltage	Varistor Voltage	Surge Capacity
100 to 120 VAC	240 to 270 V	1,000 A min.
200 to 240 VAC	430 to 470 V	1,000 A min.

Control Panel Installation

Installing an SSR in a closed control panel will cause the heat that is generated by the SSR to accumulate inside the panel, which may lessen the SSR's flow of current or possibly have adverse effects on other electronic components inside the panel.

Be sure to provide ventilation holes at the top and bottom of the control panel. The use of fans is recommended as a more effective means of ventilation.

SSR Mounting Pitch (Panel Mounting)

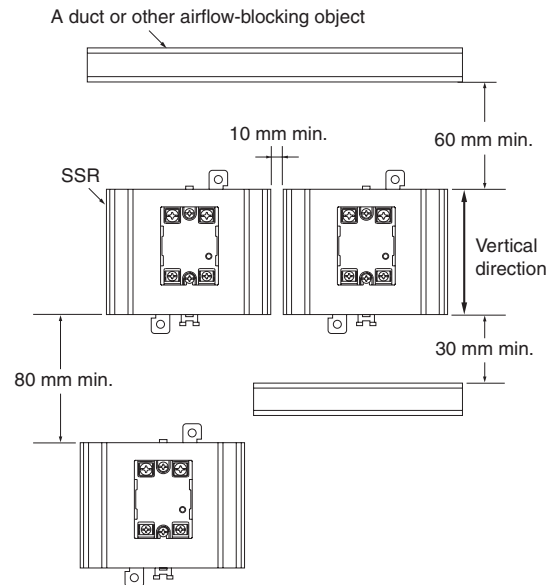

Relationship between SSRs and Duct Depth

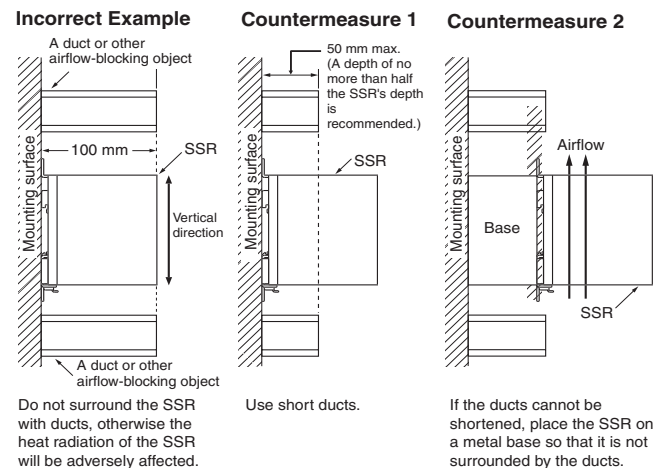

Ventilation Outside the Control Panel

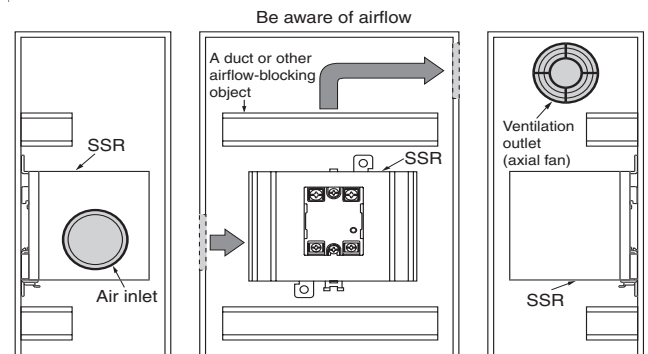

- Note:**
1. If the air inlet or air outlet has a filter, clean the filter regularly to prevent it from clogging to ensure an efficient flow of air.
 2. Do not locate any objects around the air inlet or air outlet, otherwise the objects may obstruct the proper ventilation of the control panel.
 3. A heat exchanger, if used, should be located in front of the SSRs to ensure the efficiency of the heat exchanger.

SSR Ambient Temperature

The rated load current of an SSR is measured at an ambient temperature of 40°C.

An SSR uses a semiconductor in the output element. This causes the temperature inside the control panel to increase due to heating resulting from the passage of electrical current through the load. To restrict heating, attach a fan to the ventilation outlet or air inlet of the control panel to ventilate the panel. This will reduce the ambient temperature of the SSRs and thus increase reliability. (Generally, each 10°C reduction in temperature will double the expected life, according to the Arrhenius Equation.)

SSR rated current (A)	5 A	10 A	20 A	25 A	40 A
Required number of fans per SSR	0.08	0.16	0.31	0.4	0.62

Example: For ten SSRs with load currents of 40 A,
 $0.62 \times 10 = 6.2$
 Thus, seven fans would be required.

- Note:**
1. Size of fans: 92 mm², Air volume: 0.7 m³/min, Ambient temperature of control panel: 30°C
 2. If there are other instruments that generate heat in the control panel other than SSRs, additional ventilation will be required.

Operating Conditions

- As protection against accidents due to short-circuiting, be sure to install protective devices, such as fuses and no-fuse breakers, on the power supply side.
- Do not apply overvoltages to the input circuit or output circuit. Failure or burning may result.
- Keep the cooling system running continuously during the ON/OFF operation of the SSR. This is to allow residual heat to dissipate while the SSR is OFF.

Operating Ambient Temperature

The rated value for the ambient operating temperature of the G3NB is for when there is no heat build-up. For this reason, under conditions where heat dissipation is not good due to poor ventilation, and where heat may build up easily, the actual temperature of the G3NB may exceed the rated value resulting in malfunction or burning.

When using the G3NB, design the system to allow heat dissipation sufficient to stay below the *Load Current vs. Ambient Temperature* characteristic curve. Note also that the ambient temperature of the G3NB may increase as a result of environmental conditions (e.g., climate or air-conditioning) and operating conditions (e.g., mounting in an airtight panel).

Noise Terminal Voltage According to EN55011

The G3NB-240B-UTU complies with EN55011 standards when a capacitor is connected to the load power supply as shown in the following circuit diagram.

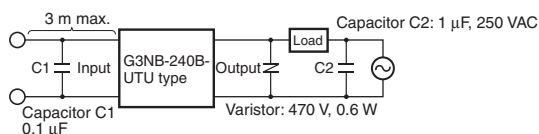

- Connect capacitor C1 to both sides of the input terminals for a G3NB with a DC input.

- Connect capacitor C2 to both sides of the load power supply output.
- Connect the varistor to both sides of the G3NB output terminals.
- Do not use an input line that is longer than 3 m.

Loss Time

The loss time will increase when the G3NB is used at a low applied voltage or current. Be sure that this does not cause any problems.

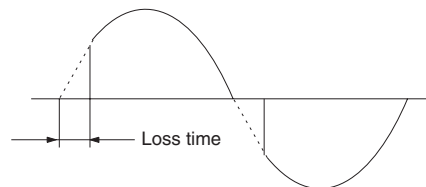

Fuses

Connect a quick-break fuse in series with the load as a short-circuit protection measure. Use one of the fuses in the following table or one with equivalent or better characteristics.

Recommended Fuses

G3NB rated load current	Fuse model	Manufacturer	Applicable SSR
40 A	50SHA40	Kyosan Electric Manufacturing Company	G3NB

Leakage Current

A leakage current flows through a snubber circuit in the G3NB even when there is no power input. Therefore, always turn OFF the power to the input or load and check that it is safe before replacing or wiring the G3NB.

