

Two-circuit Limit Switch WL



Wide Selection of Two-circuit Limit Switches

- A wide selection of models are available, including the overtravel models with greater OT, lamp-equipped models for checking operation, low-temperature and heat-resistant models, and microload models.
- Microload models are added to the product lineup.
- Meets EN/IEC standards (only Switches with ground terminals).
- Switches with ground terminals have the CE marking.



Model Number Structure

Model Number Legend

General-purpose Models/Environment-resistant Models

WL -

1 2 3 4 5 6 7 8 9 10

1. Electrical Rating

- Blank: Standard
- 01: Micro

2. Actuator and Head Specifications

Symbol	Actuator type
CA2	Roller lever: Standard model (R38)
CA2-7	Roller lever: Standard, standard model (R50)
CA2-8	Roller lever: Standard, standard model (R63)
H2	Roller lever: Overtravel, general-purpose model, 80°
G2	Roller lever: Overtravel, high-sensitivity, 80°
CA2-2N	Roller lever: Overtravel, 90°
GCA2	Roller lever: High-precision
CA12	Adjustable roller lever: Standard
H12	Adjustable roller lever: Overtravel, general-purpose model, 80°
G12	Adjustable roller lever: Overtravel, high-sensitivity, 80°
CA12-2N	Adjustable roller lever: Overtravel, 90°
CL	Adjustable rod lever: Standard
HL	Adjustable rod lever: Overtravel, general-purpose model, 80°, 25 to 140 mm
HLAL4	Adjustable rod lever: Overtravel, general-purpose model, 80°, 350 to 380 mm
GL	Adjustable rod lever: Overtravel, high-sensitivity, 80°, 25 to 140 mm
CL-2N	Adjustable rod lever: Overtravel, 90°, 25 to 140 mm
HAL5	Rod spring lever: Protective, Overtravel, general-purpose model, 80°
CA32-41	Fork lever lock: Protective, WL-5A100
CA32-42	Fork lever lock: Protective, WL-5A102
CA32-43	Fork lever lock: Protective, WL-5A104
D	Plunger: Top plunger
D2	Plunger: Top-roller plunger
D28	Plunger: Sealed top-roller plunger
D3	Plunger: Top-ball plunger
SD	Plunger: Horizontal plunger

Switches without levers

- WLRCA2
- WLRCA2
- WLRCA2
- WLRH2
- WLRG2
- WLRCA2-2N
- WLRGCA2
- WLRCA2
- WLRH2
- WLRG2
- WLRCA2-2N
- WLRCL
- WLRH2
- WLRH2
- WLRG2
- WLRCA2-2N
- WLRH2
- WLRCA32
- WLRCA32
- WLRCA32
-
-
-
-
-

Symbol	Actuator type	Switches without levers
SD2	Plunger: Horizontal-roller plunger	---
SD3	Plunger: Horizontal-ball plunger	---
NJ	Flexible rod: Coil spring	---
NJ-30	Flexible rod: Coil spring, multi-wire	---
NJ-2	Flexible rod: Coil spring, resin rod	---
NJ-S2	Flexible rod: Steel wire	---

3. Environment-resistant Model Specifications

- Blank: Standard
- RP: Corrosion-proof (See note 1.)
- P1: Weather-resistant (See note 1.)

4. Built-in Switch Specifications

- Blank: General-purpose built-in switch
- 55: Hermetically-sealed built-in switch (See note 1.)

5. Temperature Specifications

- Blank: Standard: -10°C to 80°C
- TH: Heat-resistive: 5°C to 120°C (See note 1.)
- TC: Low temperature: -40°C to 40°C (See note 1.)

6. Special Hermetic Model Specifications

- Blank: No cables or molding
- 139: General-purpose built-in switch with cables attached and molded conduit opening and cover (cover cannot be removed). (See note 1.)
- 140: Airtight built-in switch with cables attached and molded conduit opening, cover, and case cover (cover cannot be removed). (See note 1.)
- 141: Airtight built-in switch with cables attached and molded conduit opening, cover, and case cover (cover cannot be removed). The Head opening is created to protect it from cutting powder. (See note 1.)
- 145: Airtight built-in switch with cables attached and molded conduit opening, cover, and case cover (cover cannot be removed, Head can be mounted in any of 4 directions). The Head opening is created to protect it from cutting powder. (See note 1.)
- RP40: Airtight built-in switch with cables attached, SC Connector can be used, molded conduit opening, cover, and case cover (cover cannot be removed, Head direction can be changed). (See note 1.)
- RP60: Airtight built-in switch with cables attached, fluorine rubber-molded conduit opening, cover, and case cover (cover cannot be removed, Head direction cannot be changed). (See note 1.)

7. Conduit Size, Ground Terminal Specifications (See note 2.)

- Blank: G 1/2 Without ground terminal
- G1: G 1/2 With ground terminal
- G: Pg13.5 With ground terminal
- Y: M20 With ground terminal
- TS: 1/2-14NPT With ground terminal

8. Indicator Type

	Element	Voltage	Leakage Current
LE:	Neon lamp	125 VAC 250 VAC	Approx. 0.6 mA Approx. 1.9 mA
LD:	LED	10 to 115 VAC/VDC	Approx. 0.5 mA

9. Lamp Wiring

- 2: NC connection: Light-ON when operating
- 3: NO connection: Light-ON when not operating

10. Lever Type

- Blank: Standard lever
- A: Double nut lever

- Note:** 1. For information on applicable models, see page 94.
 2. Switches with ground terminals meet EN/IEC standards (and have the CE marking).

Ground Terminal Models

WL -
 1 2

1: Type of actuator
 2: Conduit opening size
 The models differ depending on the size of the case's conduit thread.

Model	Conduit opening size
G1	G 1/2
G	Pg 13.5
Y	M20
TS	1/2-14NPT

Sensor I/O Connector Models

WL - LD
 1 2 3 4

1. Electrical Rating

Blank: Standard
 01: Microload

2. Actuator Type

CA2: Roller lever: Standard
 GCA2: Roller lever: High-precision
 H2: Roller lever: Overtravel, general-purpose
 G2: Roller lever: Overtravel, high-sensitivity
 D2: Plunger: Top-roller plunger
 D28: Plunger: Sealed top-roller plunger

3. Built-in Switch Type

Blank: Standard
 55: Hermetically sealed

4. Wiring Specifications

K13A: Direct-wired Connector
 (2-core: AC, NO wiring, connector pins No. 3, 4)
 K13: Direct-wired Connector
 (2-core: DC, NO wiring, connector pins No. 3, 4)
 K43A: Direct-wired Connector (4-core: AC)
 K43: Direct-wired Connector (4-core: DC)
 -M1J: Pre-wired Connector (See note 2.)
 (2-core: DC, NO wiring, connector pins No. 3, 4)
 -M1GJ: Pre-wired Connector (See note 2.)
 (See note 1.) (2-core: DC, NO wiring, connector pins No. 1, 4)
 -M1JB: Pre-wired Connector (See note 2.)
 (See note 1.) (2-core: DC, NC wiring, connector pins No. 3, 2)
 -AGJ03: Pre-wired Connector (See note 2.) (4-core, AC)
 -DGJ03: Pre-wired Connector (See note 2.) (4-core, DC)
 (See note 1.)
 -DK1EJ03: Pre-wired Connector (See note 2.)
 (See note 1.) (3-core: DC, NO wiring, connector pins No. 2, 3, 4)

Note: 1. Models with pre-wired connectors and DC specifications have EN/IEC approval.
 2. With 0.3-m cable attached.

Direct-wired Connector

Pre-wired Connector

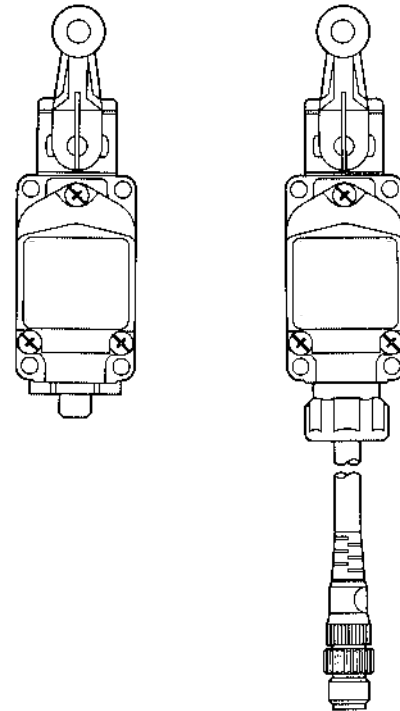

Spatter-prevention Models

WL - S
 1 2 3 4 5

1. Electrical Rating

Blank: Standard
 01: Microload

2. Actuator Type

CA2: Roller lever: Standard model
 GCA2: Roller lever: High-precision model
 H2: Roller lever: Overtravel, general-purpose model
 G2: Roller lever: Overtravel, high-sensitivity model
 D28: Plunger: Sealed top-roller plunger

3. Built-in Switch Type

Blank: Standard
 55: Hermetically sealed

4. Indicator Lamp

Blank: None
 LD: LED indicator lamp (AC/DC common)
 LE: Neon Lamp

5. Wiring Specifications

-M1J-1: Pre-wired Connector (See note.)
 (2-core: DC, NO wiring, connector pins No. 3, 4)
 -M1GJ-1: Pre-wired Connector (See note.)
 (2-core: DC, NO wiring, connector pins No. 1, 4)
 -DGJS03: Pre-wired Connector (See note.) (4 core, DC)

Note: With 0.3-m cable attached.

Ordering Information

Classification

Specifications		Standard	Overtravel	High-precision	Features	Page	
Actuators	Roller lever	Yes	Yes	Yes	Five models: Roller lever, adjustable roller lever, adjustable rod lever, fork lever lock, rod spring lever.	111 to 128	
	Plunger	Yes	---	---	Six models: Top plunger, top-roller plunger, top-ball plunger, horizontal plunger, horizontal-roller plunger, horizontal-ball plunger.	96 to 98	
	Flexible rod	Yes	---	---	Two models: coil spring and steel wire.	103, 107 to 109	
Load/contact	Standard load	SPST-NO/SPST-NC type	Yes		Standard models use a two-circuit double-break switch.		
	Microload	SPST-NO/SPST-NC type	Yes		Specifications include gold-plated contacts.		
Environment-resistant models (See note 3.)	Airtight-seal	WL□-55	Yes (Cannot be used with heat-resistant and low-temperature models.)		Uses an airtight-sealed built-in switch.	100, 110	
	Hermetic seal	Molded terminals		WL□-139			Lead wires are attached. The case cover and conduit section are molded from epoxy resin to improve sealing performance.
				WL□-140 WL□-141 WL□-145			Lead wires are attached. The case is filled with epoxy resin, to ensure high sealing performance. The Head opening is protected from cutting powder. (WL□-141 and -145 models) Only WLG2, WLCA2, and WLGCA2 can be fabricated. (WL□-141 models.)
	Anti-coolant	WL□-RP40			The connector can be removed, so it is possible to use flexible wires in the cable. The Head can be removed.		
WL□-RP60			Rubber parts are made from fluorine rubber. The Head cannot be removed.				
	Spatter-prevention	WL□-S	Yes		To improve spatter prevention during welding, a heat-resistant resin is used, and screws and rollers are all made from stainless steel.	101, 103, 105, 107, 110, 123	

Specifications		Standard	Overtravel	High-precision	Features	Page
Environment-resistant models (See note 3.)	Heat-resistive	WL□-TH	Yes (Cannot be used with airtight, hermetic, low-temperature, corrosion-proof, or lamp-equipped models.)		To improve heat resistance, silicone rubber is used for rubber parts and for the built-in switch. The operating temperature range is +5°C to 120°C.	100
	Low-temperature	WL□-TC	Yes (Cannot be used with airtight, hermetic, heat-resistive, corrosion-proof, or lamp-equipped models.)		To improve low temperature resistance, silicone rubber is used. The operating temperature range is -40°C to 40°C.	
	Corrosion-proof (See note 4.)	WL□-RP	Yes (Cannot be used with lamp-equipped models.)		Diecast parts such as the switch box are made of corrosion-proof aluminum. Rubber-sealing parts are made of fluorine rubber and exposed nuts and screws are made of stainless steel. These all aid in resisting oil, chemicals and adverse weather conditions.	
	Outdoor specifications	WL□-P1	--- (See note 5.)	Yes (See note 6.)	---	
Lamp-equipped	WL□-LE	Yes			Operating status can be checked at a glance. Lit when operating and not lit when not operating. WL□-LE: 100 VAC/VDC min. WL□-LD: 115 VAC/VDC min. (Refer to page 105 for detailed ratings.)	98, 106, 107, 109, 120
	WL□-LD	Yes				
Relevant pages		Pages 111 to 128			---	---

- Note:**
- Do not expose to extreme changes in temperature.
 - Standard Models: Operate on each side at an angle of 45°. Possible to set to one-side operation on either side. Pretravel (PT) is 15°.
Overtravel Models: Standard and high-sensitivity models operate on each side at an angle of 80°. Not possible to set to one-side operation. -2N Series operate on each side at an angle of 90°. Possible to set to one-side operation on either side.
High-precision Models: Operate on each side at an angle of 45°. Possible to set to one-side operation on either side. Pretravel (PT) is 5°.
 - When ordering, add the suffix for the environment-resistant model or indicator specifications required according to the operating environment and purpose.
 - The overtravel model (-2N Series), fork lever lock model (WLCA32-41 to 44), horizontal plunger (WLS□) model, heat-resistive model, low-temperature model, and lamp-equipped model cannot be used with the corrosion-proof model.
 - Outdoor specifications are available for some standard models. Consult your OMRON representative for details.
 - Outdoor specifications are only available for general models and high-sensitivity models.

■ List of Models

General-purpose Models





These Limit Switches are two-circuit double-break switches housed in rugged diecast, thus making it an oil-tight, waterproof and dustproof construction (complies with IP67).

In addition to the standard models, microload models are also available.

A wide range of actuators with a range of functions are available; rotating lever, plunger, flexible rod etc.

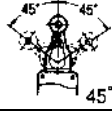
The rubber material in the standard models is designed to be resistant to water and most oils.

Roller Lever Models: Short, Medium, and Long Lever Models

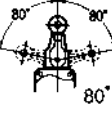
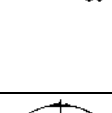
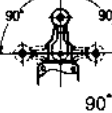
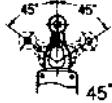



Type	Total travel (TT)	Features	Actuator (See note 2.)		
			WL-1A100 Roller Lever: Short lever (R38)	WL-1A200 Roller Lever: Medium lever (R50)	WL-1A300 Roller Lever: Long lever (R63)
Standard		One-side operation is possible. (See note 3.) Head can be mounted in any of the four directions.	WLCA2 	WLCA2-7 	WLCA2-8 
Over-travel	General 	One-side operation is impossible. (See note 3.) Head can be mounted in any of the four directions.	WLH2	---	---
	High-sensitivity 	One-side operation is possible. (See note 3.) Head can be mounted in any of the four directions.	WLG2	---	---
	Side-installation 	One-side operation is possible. (See note 3.) Head can be mounted in any of the two directions. (When the Head can be mounted horizontally, the Head can be mounted in any of the four directions.)	WLCA2-2N	---	---
High-precision		One-side operation is possible. (See note 3.) Head can be mounted in any of the four directions.	WLGCA2	---	---

Note: 1. For the approved standards file numbers, refer to page 103.

2. For external dimensions and other information, refer to pages 111 to 128.

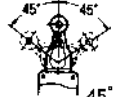

3. One-side operation means that three operational directions can be selected electrically, according to the change in direction of the operating plunger. Those models for which one-side operation is impossible can only operate on both sides. For details, see page 128.

Adjustable Roller Levers and Adjustable Rod Levers

Type	Total Travel (TT)	Features	Actuator (See note 2.)	
			WL-2A100 Adjustable Roller Lever 	WL-4A100 Adjustable Rod Lever (Adjustable length: 25 to 140 mm) WL-3A100 (Adjustable length: 350 to 380 mm) 
Standard		One-side operation possible. (See note 3.) Head can be mounted in any of the four directions.	WLCA12	---
			---	WLCL (WL-4A100)
Overtravel	General 	One-side operation possible. (See note 3.) Head can be mounted in any of the four directions.	WLVH12	WLHL (WL-4A100) WLHAL4 (WL-3A100)
			High-sensitivity	WLVG12
	Side-installation		One-side operation is possible. (See note 3.) Head can be mounted in any of the two directions. (When the Head can be mounted horizontally, the Head can be mounted in any of the four directions.)	WLCA12-2N





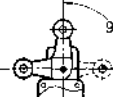
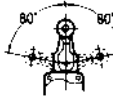

- Note:**
1. For the approved standards file numbers, refer to page 103.
 2. For external dimensions and other information, refer to pages 111 to 128.
 3. One-side operation means that three operational directions can be selected electrically, according to the change in direction of the operating plunger. The operating plunger is set for operation on both sides before delivery. Those models for which one-side operation is impossible can only operate on both sides. For details, see page 128. The operational plunger is factory-set to both sides.

Rod Spring Levers and Fork Lever Locks

Type	Total travel (TT)	Features	Actuator (See note 2.)	
			WL-3A200 Rod Spring Lever 	Fork Lever Locks: WL-5A100, WL-5A102, WL-5A104 
Protective		Head can be mounted in any of the four directions.	---	WLCA32-41 (WL-5A100) WLCA32-42 (WL-5A102) WLCA32-43 (WL-5A104)
Overtravel	General 	One-side operation is possible. (See note 3.) Head can be mounted in any of the four directions.	WLHAL5	---



- Note:**
1. For the approved standard file numbers, refer to page 103.
 2. For external dimensions and other information, refer to pages 111 to 128.
 3. One-side operation means that three operational directions can be selected electrically, according to the change in direction of the operating plunger. The operating plunger is set for operation on both sides before delivery. Those models for which one-side operation is impossible can only operate on both sides. For details, see page 128. The operational plunger is factory-set to both sides.
 4. The fork lever lock is configured so that the dog pushes the lever to reverse the output and this reversed state is maintained even after the dog continues on. If the dog then pushes the lever from the opposite direction, the lever will return to its original position.

Standard Plungers

Type	Actuators	Model
Top	Top Plunger 	WLD
	Top-roller Plunger 	WLD2 WLD28 (See note.)
	Top-ball Plunger 	WLD3
Horizontal	Horizontal Plunger 	WLS D
	Horizontal-roller Plunger 	WLS D2
	Horizontal-ball Plunger 	WLS D3

Note: Sealed roller.

Standard Flexible Rods

Actuators		Model
Coil spring 	Spring dia. 6.5	WLNJ
	Spring dia. 4.8	WLNJ-30
	Resin rod dia. 8.0	WLNJ-2
Steel wire 	1.0-dia. wire	WLNJ-S2

Microload Models

A series of microload models has also been developed for the configurations outlined on pages 96 to 98. The model numbers become WL01□. For example, WLCA2 becomes WL01CA2.

Lamp-equipped Models

Operating characteristics	Rated voltage	Leakage current	Lamp-equipped Switch	Lamp-equipped cover only
Neon lamp	125 VAC	Approx. 0.6 mA	WL□-LE (See note 1.)	WL-LE
	250 VAC	Approx. 1.9 mA		
LED	10 to 115 VAC/VDC	Approx. 0.5 mA	WL□-LD (See note 1.)	WL-LD

Note: 1. In the model number, □ indicates the actuator number. For example, CA2, D, NJ, etc.

2. The default setting is "light-ON when not operating." Turn the lamp holder by 180° to change the setting to "light-ON when operating."

Ordering Information

When ordering general-purpose indicator-equipped models insert the specifications number at the end of the basic model number.

E.g.: When a neon lamp is installed in a General-purpose/Standard Roller Lever Switch (WLCA2).

<u>WLCA2</u>	<u>LE</u>
↑	↑
Standard	Lamp specifications

When ordering indicator-equipped molded terminal models, insert the specifications number at the end of the standard model number.

E.g.: When a Neon Lamp (WL-LE) is installed in a general-purpose molded terminal model (WLCA2-139).

<u>WLCA2-139</u>	<u>LE</u>	<u>2</u>
↑	↑	↑
Standard	Lamp specifications	Lamp wiring

2: NC connection: Light-ON when operating
3: NO connection: Light-ON when not operating

Note: The indicator cover cannot be replaced on the molded terminals. In all cases the indicator does not light when the load is ON.

Sensor I/O Connector Models

A reduction in the amount of wiring and parts makes maintenance easy and reduced wiring mistakes, in addition it's already compact size for fitting into areas of limited space.

Ordering Information

Item		Standard	Overtravel	High sensitivity
Actuators	Rotating lever	Yes	Yes	Yes
	Plunger	Yes	---	---
Load	Standard load (SPST-NO/SPST-NC)	Yes		
	Microload (SPST-NO/SPST-NC)	Yes		
High-precision models WL-□55		Yes		
Spatter-prevention models (See note 3.)		Yes		
Lamp		Yes		

- Note:** 1. Standard Models: For standard models only one-side operation at an angle of 45° is possible.
 Overtravel Models: Only one-side operation at an angle of 80° is possible. One-side operation only is not possible.
 High-precision Models: Only one-side operation at an angle of 45° is possible, and pretravel (PT) is 5°, as opposed to 15° for standard models.
2. For information other than that listed at the above, contact your OMRON representative.
3. The spatter-prevention models are only available as pre-wired connectors.

Direct-wired Connectors

Type	2-core (NO)	4-core
Lamp-equipped	WL□-LDK13	WL□-LDK43
Double-seal	WL□-55LDK13	WL□-55LDK43

- Note:** 1. In the model number, □ indicates the actuator number. For example, Overtravel Model WL $\hat{G}2$ -LDK13.
2. The lamp is set to "light-ON when not operating" (NO connection).

Pre-wired Connectors

Type	2-core (NO)	2-core (NC)	4-core	3-core (NO)
Lamp-equipped	WL□-LD-M1J	WL□-LD-M1JB	WL□-LD-DGJ03	WL□-LD-DK1EJ03
Double-seal	WL□-55LD-M1J	WL□-55LD-M1JB	WL□-55LD-DGJ03	WL□-55LD-DK1EJ03

- Note:** 1. In the model number, □ indicates the actuator number. For example, Overtravel Model WL $\hat{G}2$ -LD-M1J.
2. The lamp is set to "light-ON when not operating" (NO connection).

Environment-resistant Models

Airtight, Hermetic Seal, Low-temperature, Heat-resistive, Corrosion-proof, and Weather-resistant Models

Using the general-purpose model, six types of environment-resistant models can be created to meet a variety of difficult operating conditions. Select the model most appropriate to your operating environment.

Type		Usage	Environment-resistant construction			Appropriate models
WL□-55	Airtight seal	For use in locations subject to splashes of water and anti-coolant	Uses the W-10FB3-55 Airtight Built-in Switch. (See note 2.)			All models except the low-temperature and heat-resistive models. (See note 3.)
WL□-139	Hermetic seal (molded terminals and anti-coolant models)		General-purpose built-in switch	Connection lead wires: Standard 5-m VCT (vinyl cabtire cable) cable attached. Finished diameter: 11.5 mm, 4-core.	The case cover and conduit opening are molded from epoxy resin. The cover cannot be removed.	All models except the low-temperature and heat-resistive models. (See note 4.)
WL□-140			Hermetically-sealed built-in switch	Connection lead wires: Standard 5-m VCT cable, with high flexibility and good anti-oil properties attached. Finished diameter: 11.5 mm, 4-core.	The case cover, cover box and conduit opening are molded from epoxy resin. The cover cannot be removed (141, 145). The Head opening is protected from cutting powder. (WL□-141)	
WL□-141					The connector can be removed, so it is possible to use flexible wires in the cable.	
WL□-145						
WL□-RP40					Rubber parts are made from fluorine rubber.	
WL□-RP60						
WL□-TC	Low-temperature	Can be used at a temperature of -40°C (The operating temperature range is -40°C to 40°C), but cannot withstand icing.	Uses the general-purpose built-in switch. Silicone rubber is used for rubber parts such as the O-ring, gasket, etc.			All models except airtight, hermetic, heat-resistive, corrosion-proof, or lamp-equipped models.
WL□-TH	Heat-resistive	Can be used in temperatures of 120°C (The operating temperature range is 5°C to 120°C).	Uses a special built-in switch made from heat-resistant resin. Silicone rubber is used for rubber parts such as the O-ring, gasket etc.			All models except airtight, hermetic, low-temperature, corrosion-proof, lamp-equipped, nylon roller (WLCA2-26N), seal roller models, and resin rod (WLNJ-2) models.
WL□-RP	Corrosion-proof	For use in locations subject to corrosive gases and chemicals.	Diecast parts such as the switch box are made of corrosion-proof aluminum. Rubber sealing parts are made of fluorine rubber which aids in resisting oil, chemicals and adverse weather conditions. Exposed nuts and screws (except the actuator section) are made of stainless steel. Moving and rotary parts such as rollers are made of sintered stainless steel or stainless steel.			All models except overtravel model (-2N), fork lever lock models (WLCA32-41 to -43), low-temperature, heat-resistive, and lamp-equipped models.
WL□-P1	Outdoor specifications	For use in parking lots and other such outdoor locations.	Rubber parts are made from silicone rubber, which has a high-tolerance to deterioration over time, and changes in temperature. Rollers are made of stainless steel to improve corrosion resistance. Exposed nuts and screws are made of stainless steel.			Only the general-purpose overtravel models (WLH2/12), the overtravel high-sensitivity models (WLG2/12) and some standard models (e.g., WLCA2) can be used. Excluding heat-resistive models.

- Note:**
1. Consult your OMRON representative for the microload WL01□ models.
 2. Use the SC Connector for the conduit opening.
 3. The actuator can be created using the standard model.

4. The actuator can be created using the standard model. For WL-□141 and -145, only WLG2, WLCA2, WLGA2, and WLH2 can be used.

Ordering Information

Use the following as a guide when ordering environment-resistant models.

E.g.: For a hermetic model of WLCA2





WLCA2 - 55
 ↑ ↑
 Standard Specifications No.

An additional catalog is available for outdoor specifications models.

Spatter-prevention Models

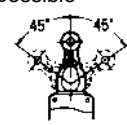

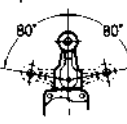
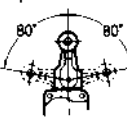
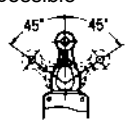

These models are most effective in an arc welding line or places where cutting powder is spattered.

Standard Models

Type	Total travel (TT)	Actuators	Neon lamp		LED	
			125 VAC	250 VAC	10 to 115 VAC/DC	
			Approx. 0.6 mA	Approx. 1.9 mA	Approx. 0.5 mA	
Standard	One-side operation is possible 	Double nut lever 	WLCA2-LEAS		WLCA2-LDAS	
		Allen-head lever 	WLCA2-LES		WLCA2-LDS	
Overtravel	General One-side operation is impossible 	Double nut lever	WLH2-LEAS		WLH2-LDAS	
		Allen-head lever	WLH2-LES		WLH2-LDS	
	High-sensitivity	One-side operation is impossible 	Double nut lever	WLG2-LEAS		WLG2-LDAS
			Allen-head lever	WLG2-LES		WLG2-LDS
High-precision	One-side operation is possible 	Double nut lever 	WLGA2-LEAS		WLGA2-LDAS	
		Allen-head lever 	WLGA2-LES		WLGA2-LDS	

Note: Consult your OMRON representative for the microload WL01□ models.







Levers/Lamp-equipped Covers

Type	Without lever 	Complete Head (lever with Head) 	Double nut lever 	Allen-head lever 	Lamp-equipped cover 
Model	Add an "R" to the product number to order. E.g.: WL□CA2-LES	WL-1H1100S (in case of WLCA2-□, WLGA2-□) WL-2H1100S (in case of WLH2-□, WLG2-□)	WL-1A105S (forward and backward lever)	WL-1A103S (forward and backward lever)	WL-LES (Neon Lamp) WL-LDS (LED)

Switches Without Lever

WLRCA2-LES, WLRCA2-LDS
 WLRH2-LES, WLRH2-LDS, WLRG2-LES
 WLRG2-LDS
 WLRGCA2-LES, WLRGCA2-LDS

Head Models

Actuators	Set model	Head model	Head model without lever
Roller lever 	WLCA2	WL-1H1100	WLRCA2
	WLGCA2	WL-1H1100-1 (See note.)	WLRGCA2
	WLG2	WL-2H1100	WLRG2
	WLH2	WL-2H1100-1 (See note.)	WLRH2
	WLCA2-2N	WL-6H1100	WLRCA2-2N
Adjustable roller lever 	WLCA12	WL-1H2100	WLRCA2
	WLG12	WL-2H2100	WLRG2
	WLH12	WL-2H2100-1 (See note.)	WLRH2
	WLCA12-2N	WL-6H2100	WLRCA2-2N
Adjustable rod lever 	WLCL	WL-4H4100	WLRCL
	WLGL	WL-2H4100	WLRG2
	WLCL-2N	WL-6H4100	WLRCA2-2N
Top plunger 	WLD	WL-7H100	---
	WLD2	WL-7H200	
	WLD3	WL-7H300	
	WLD28	WL-7H400	
Horizontal plunger 	WLSD	WL-8H100	---
	WLSD2	WL-8H200	
	WLSD3	WL-8H300	
Fork lever lock 	WLCA32-41	WL-5H5100	WLRCA32
Coil spring 	WLNJ	WL-9H100	---
	WLNJ-30	WL-9H200	
	WLNJ-2	WL-9H300	
	WLNJ-S2	WL-9H400	

Note: For the model number of Heads without lever, simply remove the numbers after WL-□H. For example, WL-1H1100 becomes WL-1H. WLH2 and WLH12 however, become WL-2H-1, and WLGCA2 becomes WL-1H-1. Other Head models are available, but must be ordered separately.

Specifications

■ Approved Standards

Agency	Standard	File No.
UL	UL508	E76675
CSA	CSA C22.2 No. 14	LR45746
TÜV Rheinland	EN60947-5-1	R9551016

Note: Contact your OMRON representative for more information on approved models.

■ Approved Standard Ratings

General-purpose Models

UL/CSA

Standard Models: A600

Rated voltage	Carry current	Current		Volt-amperes	
		Make	Break	Make	Break
120 VAC	10 A	60 A	6 A	7,200 VA	720 VA
240 VAC		30 A	3 A		
480 VAC		15 A	1.5 A		
600 VAC		12 A	1.2 A		

Microload Models:

0.1 A at 125 VAC, 0.1 A at 30 VDC

TÜV (EN60947-5-1)

(Only Ground Terminal Models are Approved)

Model	Category/rating	Thermal current	Indicator
WL□-□	AC-15 2 A/250 V DC12 2 A/48 V	10 A	---
WL01□	AC-14 0.1 A/125 V DC12 0.1 A/48 V	0.5 A	---
WL□-LE	AC-15 2 A/250 V	10 A	Neon lamp
WL01□-LE	AC-14 0.1 A/125 V	0.5 A	Neon lamp
WL□-LD	AC-15 2 A/115 V DC12 2 A/48 V	10 A	LED
WL01□-LD	AC-14 0.1 A/115 V DC12 0.1 A/48 V	0.5 A	LED

Note: As an example, AC-15 2 A/250 V means the following:

Application category	AC-15
Rated operating current (Ie)	2 A
Rated operating voltage (Ue)	250 V

Spatter-prevention Models

UL/CSA

LE (Neon Lamp) A300

Rated voltage	Carry current	Current		Volt-amperes	
		Make	Break	Make	Break
120 VAC	10 A	60 A	6 A	7,200 VA	720 VA
240 VAC		30 A	3 A		

LD (LED)

Rated voltage	Carry current
115 VAC	10 A
115 VDC	0.8 A

■ Ratings

General-purpose Models/Environment-resistant Models

Standard Load Models

Type	Rated voltage	Non-inductive load				Inductive load			
		Resistive load		Lamp load		Inductive load		Motor load	
		NC	NO	NC	NO	NC	NO	NC	NO
Standard, overtravel (except high-sensitivity models), and high-precision models.	125 VAC	10 A		3 A	1.5 A	10 A		5 A	2.5 A
	250 VAC	10 A		2 A	1 A	10 A		3 A	1.5 A
	500 VAC	10 A		1.5 A	0.8 A	3 A		1.5 A	0.8 A
	8 VDC	10 A		6 A	3 A	10 A		6 A	
	14 VDC	10 A		6 A	3 A	10 A		6 A	
	30 VDC	6 A		4 A	3 A	6 A		4 A	
	125 VDC	0.8 A		0.2 A	0.2 A	0.8 A		0.2 A	
	250 VDC	0.4 A		0.1 A	0.1 A	0.4 A		0.1 A	
Overtravel (high-sensitivity models)	125 VAC	5 A		---		---		---	
	250 VAC	5 A		---		---		---	
	125 VDC	0.4 A		---		---		---	
	250 VDC	0.2 A		---		---		---	

- Note:**
- The above figures are for standard currents.
 - Inductive loads have a power factor of 0.4 min. (AC) and a time constant of 7 ms max. (DC).
 - Lamp load has an inrush current of 10 times the steady-state current.
 - Motor load has an inrush current of 6 times the steady-state current.
 - For PC loads, use the microload models.

Inrush current	NC	30 A max. (15 A max. (See note.))
	NO	20 A max. (10 A max. (See note.))

Note: Only for high-sensitivity overtravel models.

Microload Models

Rated voltage	Resistive load
125 VAC	0.1 A
30 VDC	

Operation within the three zones illustrated in the following diagram will produce optimum performance.

Recommended Load Range: 5 to 30 VDC, 0.5 to 100 mA

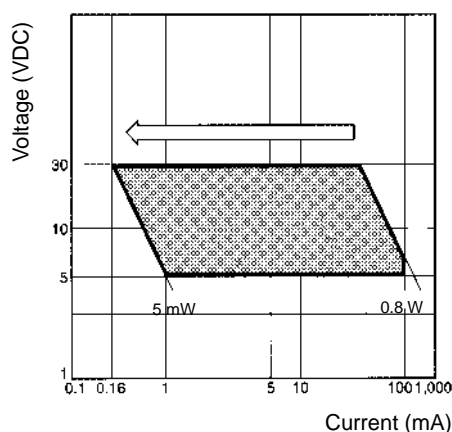

Lamp-equipped Models

Neon lamp (WL-LE)		LED (WL-LD)
125 VAC	250 VAC	10 to 115 VAC/DC
Approx. 0.6 mA	Approx. 1.9 mA	Approx. 0.5 mA
WLD28-LES		WLD28-LDS

Sensor I/O Connector Models

Type	Rated voltage	Non-inductive load				Inductive load			
		Resistive load		Lamp load		Inductive load		Motor load	
		NC	NO	NC	NO	NC	NO	NC	NO
For DC	12 VDC	1 A	1 A	1 A	1 A	1 A	1 A	1 A	1 A
	24 VDC	1 A	1 A	1 A	1 A	1 A	1 A	1 A	1 A
	48 VDC	1 A	1 A	1 A	1 A	1 A	1 A	1 A	1 A
	115 VDC	0.8 A	0.8 A	0.2 A	0.2 A	0.8 A	0.8 A	0.2 A	0.2 A
For AC	115 VAC	1 A	1 A	1 A	1 A	1 A	1 A	1 A	1 A

- Note:**
1. The above figures are for standard currents.
 2. Inductive loads have a power factor of 0.4 min. (AC) and a time constant of 7 ms max. (DC).
 3. Lamp load has an inrush current of 10 times the steady-state current.
 4. Motor load has an inrush current of 6 times the steady-state current.

Spatter-prevention Models

Model	Rated current	Non-inductive load				Inductive load			
		Resistive load		Lamp load		Inductive load		Motor load	
		NC	NO	NC	NO	NC	NO	NC	NO
WL□-LES	125 VAC	10 A		3 A	1.5 A	10 A		5 A	2.5 A
	250 VAC	10 A		2 A	1 A	10 A		3 A	1.5 A
	125 VDC	0.8 A		0.2 A	0.2 A	0.8 A		0.2 A	0.2 A
	250 VDC	0.4 A		0.1 A	0.1 A	0.4 A		0.1 A	0.1 A
WL□-LDS	115 VAC	10 A		3 A	1.5 A	10 A		5 A	2.5 A
	12 VDC	10 A		6 A	3 A	10 A		6 A	
	24 VDC	6 A		4 A	3 A	6 A		4 A	
	48 VDC	3 A		2 A	1.5 A	3 A		2 A	

- Note:**
1. The above figures are for standard currents.
 2. Inductive loads have a power factor of 0.4 min. (AC) and a time constant of 7 ms max. (DC).
 3. Lamp load has an inrush current of 10 times the steady-state current.
 4. Motor load has an inrush current of 6 times the steady-state current.

Inrush current	NC	30 A max.
	NO	20 A max.
Operating temperature	-10°C to 80°C (with no icing)	
Operating humidity	95% max.	

■ Characteristics

General-purpose Models/Environment-resistant Models

Degree of protection	IP67
Durability (See note 3.)	Mechanical: 15,000,000 operations min. (See note 4.) Electrical: 750,000 operations min. (See note 5.)
Operating speed	1 mm to 1 m/s (for WLCA2)
Operating frequency	Mechanical: 120 operations/minute min. Electrical: 30 operations/minute min.
Rated frequency	50/60 Hz
Insulation resistance	100 MΩ min. (at 500 VDC)
Contact resistance	25 mΩ max. (initial value)
Dielectric strength	1,000 VAC (600 VAC), 50/60 Hz for 1 min between non-continuous terminals. 2,200 VAC, 50/60 Hz for 1 min/Uimp 2.5 kV non-current-carrying metal part and ground. 2,200 VAC, 50/60 Hz for 1 min Uimp 2.5 kV between each terminal and non-current-carrying metal part.
Rated insulation voltage (U _i)	250 V (EN60947-5-1)
Switching overvoltage	1,000 V max. (EN60947-5-1)
Pollution degree (operating environment)	3 (EN60947-5-1)
Short-circuit protective device (SCPD)	10 A, fuse type gG or gI (IEC269)
Conditional short-circuit current	100 A (EN60947-5-1)
Conventional enclosed thermal current (I _{the})	10 A, 0.5 A (EN60947-5-1)
Protection against electric shock	Class I
Vibration resistance	10 to 55 Hz, 1.5-mm double amplitude (See note 6.)
Shock resistance	Destruction: 1,000 m/s ² min. Malfunction: 300 m/s ² min. (See note 6.)
Ambient temperature	Operating: -10°C to 80°C (with no icing) (See note 7.)
Ambient humidity	Operating: 95% max.
Weight	Approx. 275 g (in the case of WLCA2)

- Note:**
1. The above figures are initial values.
 2. The figures in parentheses for dielectric strength, are those for the overtravel (high-sensitivity) model.
 3. The values are calculated at an operating temperature of 5°C to 35°C, and an operating humidity of 40% to 70%. Contact your OMRON sales representative for more detailed information on other operating environments.
 4. 10,000,000 operations min. for general-purpose, high-sensitivity, and flexible rod overtravel models.
 5. 500,000 operations min. for high-precision and outdoor specifications models. All microload models however, are 1,000,000 operations min.
 6. Except the flexible rod models. The shock resistance (malfunction) for microload models is 200 m/s² min.
 7. For low temperature models this is -40°C to 40°C (no icing). For heat-resistant models the range is +5°C to 120°C.

■ Contact Form

General-purpose Models

Standard (WL□)/Microload (WL01□) Models

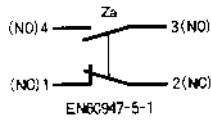
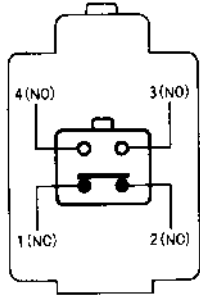

Environment-resistant Models

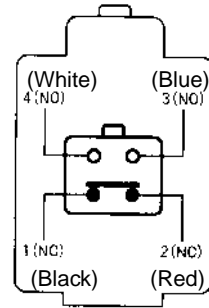

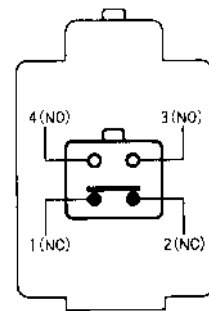

Spatter-prevention Models

Standard Model

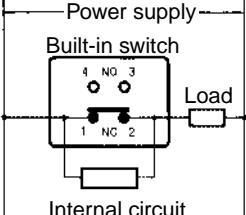

Lamp-equipped Models

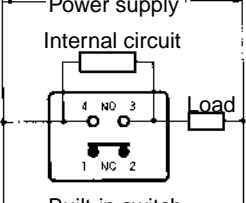
<p>Light-ON when operating (See note 1.)</p>	<p>WL-LE WL-LD</p> 	<p>Power supply</p>  <p>Built-in switch</p> <p>Internal circuit</p> <p>Load</p>
<p>Light-ON when not operating (See note 2.)</p>	<p>WL-LE WL-LD</p> 	<p>Power supply</p>  <p>Internal circuit</p> <p>Built-in switch</p> <p>Load</p>

- Note:** 1. Light-ON when operating means that the lamp lights when the Limit Switch contacts (NC) release, or when the actuator rotates or is pushed down.
 2. Light-ON when not operating means the lamp remains lit when the actuator is free, or when the Limit Switch contacts (NO) close when the actuator rotates or is pushed down.

Internal circuit of Lamp-equipped Models

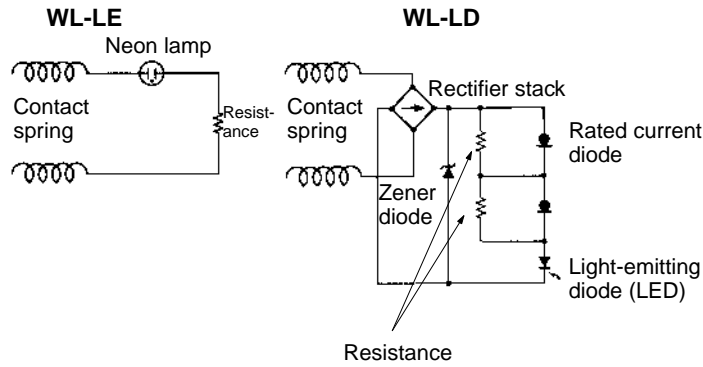

■ Wiring Specifications of Sensor I/O Connector Models

Direct-wired Connector				Pre-wired Connector									
2-core		4-core		2-core						4-core		3-core	
K13 (DC) K13A (AC)		K43 (DC) K43A (AC)		M1J (DC)		M1GJ (DC)		M1JB (DC)		DGJ03 (DC) AGJ03 (AC)		DK1EJ03 (DC)	
Built-in switch	Connector	Built-in switch	Connector	Built-in switch	Connector	Built-in switch	Connector	Built-in switch	Connector	Built-in switch	Connector	Built-in switch	Connector
1 (NC)	---	1 (NC)	1	1 (NC)	---	1 (NC)	---	1 (NC)	3	1 (NC)	1	1 (NC)	---
2 (NC)	---	2 (NC)	2	2 (NC)	---	2 (NC)	---	2 (NC)	2	2 (NC)	2	2 (NC)	2
3 (NO)	3	3 (NO)	3	3 (NO)	3	3 (NO)	1	3 (NO)	---	3 (NO)	3	3 (NO)	3
4 (NO)	4	4 (NO)	4	4 (NO)	4	4 (NO)	4	4 (NO)	---	4 (NO)	4	4 (NO)	4

Engineering Data

General-purpose Models/Spatter-prevention Models/Environment-resistant Models

Electrical Durability

Operating temperature: 5°C to 30°C
 Operating humidity: 40% to 70%.

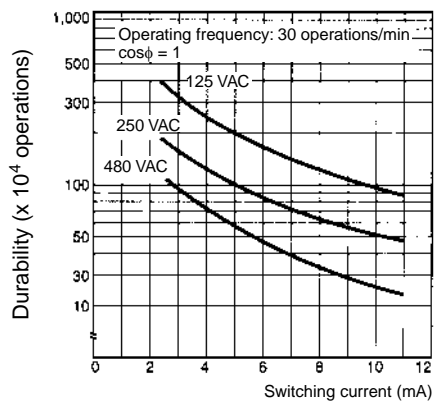

Nomenclature

General-purpose Models

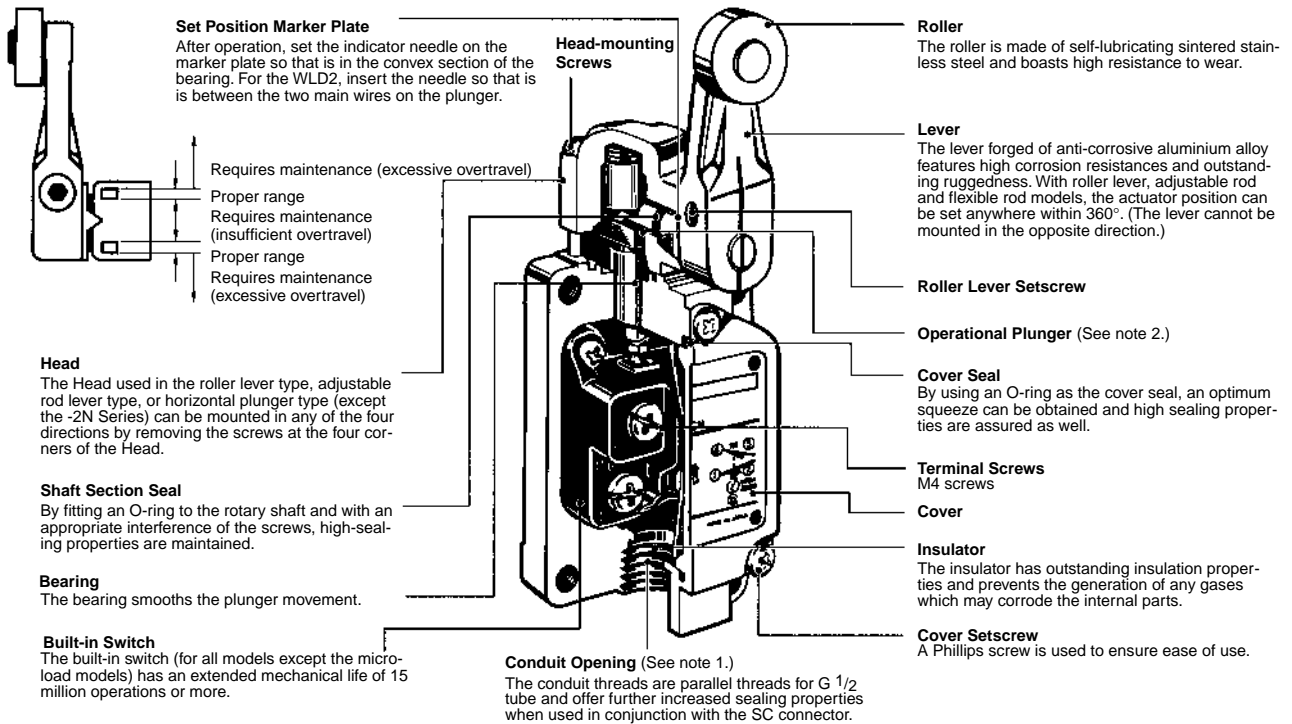

- Note:** 1. The display for conduit threads has changed from PF¹/₂ to G¹/₂ according to revisions of JIS B 0202. This is only a change in the display, so the thread size and pitch have not changed. (Conduit threads Pg 13.5 and 1/2-14NPT are also available.)
2. By changing the orientation of the operational plunger, three operational directions can be selected electrically. (This is only possible with general-purpose roller lever, adjustable roller lever, and adjustable rod lever models. For the overtravel models, only -2N Series models have this function.)

Lamp-equipped Models

The operating status of the Switch can be checked using a neon lamp of LED indicator.

Circuit checks and troubleshooting errors are easy done.

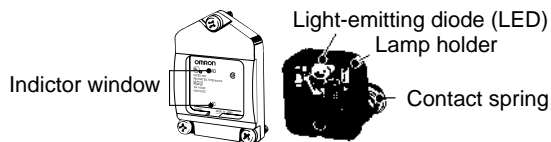

The built-in switch's terminal screws are used to connect the lamp terminal (indicator cover). Since the connection spring (coil spring) is used for this connection, it will not be necessary to connect to the lamp terminal. When a ground terminal is provided however, lead wire method must be used.

WL-LD has a built-in rectifier stack, so it will not be necessary to change the polarity.

The indicator cover is molded from diecast aluminum and has outstanding sealing properties. Furthermore, regardless of whether the power is connected or not, the operating status is shown (operating or not operating), and indicators can be switched from light-ON when operating and light-ON when not operating, by simply rotating the lamp holder by 180°. (Molded terminals do not have this switching capacity.)

The lamp-equipped models are ideal in locations using a conveyor belt where items need to be checked, or locations that are difficult to inspect for faults.

Light-ON when Operating

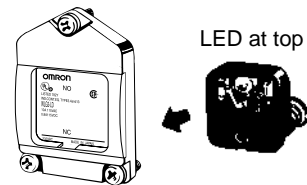

Light-ON when Not Operating

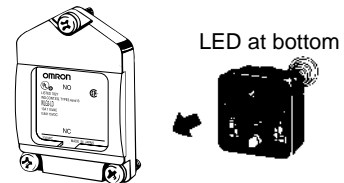

■ Environment-resistant Models

Airtight Built-in Switch

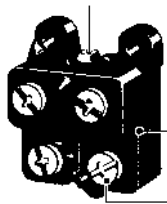

Sealed by the rubber boot of the plunger

Sealed by the resin molded into the case cover

Four, M4 ±terminal screws

Hermetic Seal Model

The lead wires are sealed to the Limit Switch with resin, providing a hermetically sealed construction.

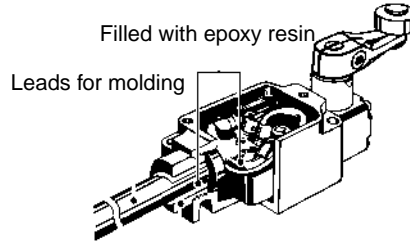

Filled with epoxy resin

Leads for molding

Exclusive connector

■ Spatter-prevention Models

Double Nut Lever

Roller, Roller Axis

Using stainless steel prevents spatter from adhering.

Operating Lever

Melamine sinter-painted, it is easy to peel off the spatter.

Lamp Cover

Heat-resistant resin is used for the lamp cover. By using spherical surface for the display part, it disperses the direction of spatter.

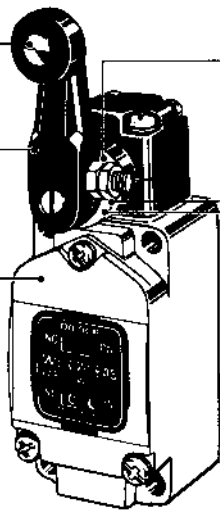

SUS304 is used for double nut.

Screws

SUS304 is used, preventing spatter from adhering.

Head Cap

Using Teflon prevents spatter from adhering.

Note: Spatter means the Zn powder produced when welding. Adhering spatter to the Limit Switch may cause malfunction of lever or lamp cover.

The lack of gap prevents spatter powder from clogging.

Dimensions

General-purpose Models

Standard Models

Note: 1. Rotating Lever Models: For all models WL□ indicates a standard model and WL01□ indicates a microload model.
 2. Unless otherwise indicated, a tolerance of ±0.4 mm applies to all dimensions.

Roller Lever

WLCA2
WL01CA2

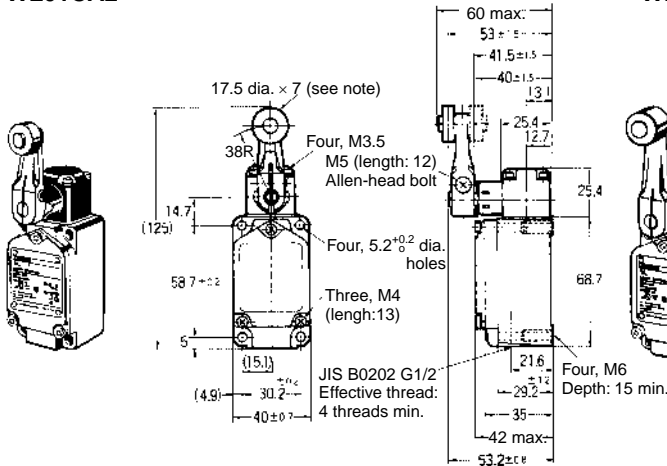

Note: Stainless sintered roller

Roller Lever

WLCA2-7
WL01CA2-7

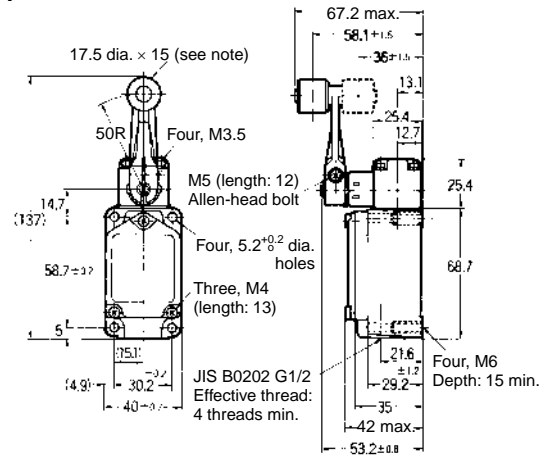

Note: Stainless steel roller

Roller Lever

WLCA2-8
WL01CA2-8

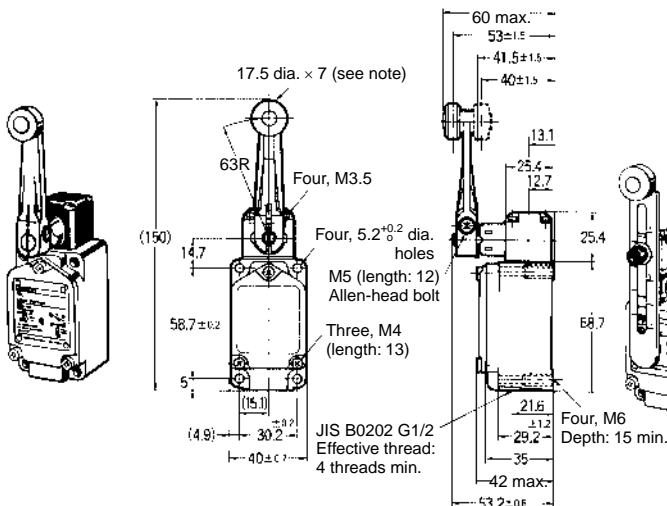

Note: Stainless sintered roller

Adjustable Roller Lever

WLCA12
WL01CA12

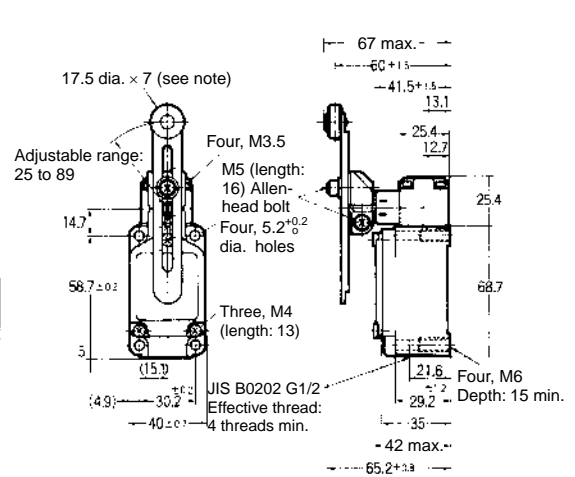

Note: Stainless sintered roller

Operating characteristics	WLCA2 WL01CA2	WLCA2-7 WL01CA2-7	WLCA2-8 WL01CA2-8	WLCA12 WL01CA12 (See note.)
Operating force: OF max.	13.34 N	10.2 N	8.04 N	13.34 N
Release force: RF min.	2.23 N	1.67 N	1.34 N	2.23 N
Pretravel: PT	15±5°	15±5°	15±5°	15±5°
Overtravel: OT min.	30°	30°	30°	30°
Movement differential: MD max.	12°	12°	12°	12°

Note: The operating characteristics for WLCA12 and WL01CA12 are measured at the lever length of 38 mm.

OF and RF for WLCA12, with a lever length of 89 mm.

Operating characteristics	WLCA12, WL01CA12
OF	5.68 N
RF	0.95 N

Rotating Lever Models: For all models WL indicates a standard model and WL01□ indicates a microload model.

Adjustable Rod Lever

WLCL
WL01CL

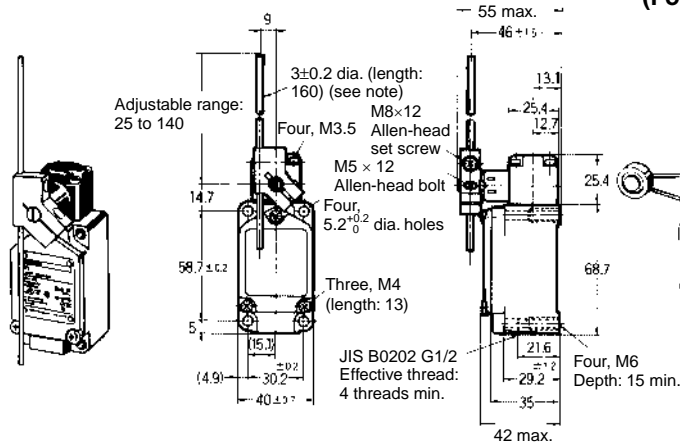

Note: Stainless steel rod

Fork Lever Lock

WLCA32-41 to 44
WL01CA32-41 to 44
(For details see pages 40 and 42.)

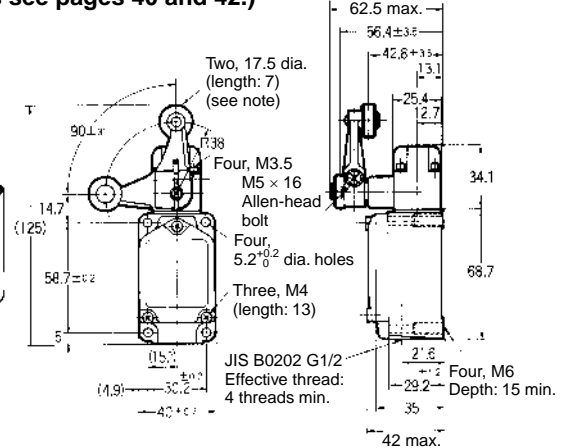

Note: Plastic roller. This illustration shows the external dimensions of the WLCA32-41. (Models WLCA32-041 to -044 and WL01CA32-041 to -044 have stainless steel rollers.)

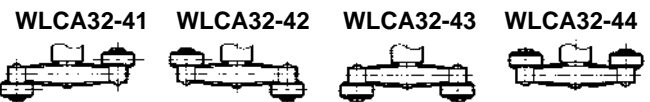

Note: Unless otherwise indicated, a tolerance of ±0.4 mm applies to all dimensions.

Operating characteristics	WLCL, WL01CL
Operating force: OF max.	1.39 N
Release force: RF min.	0.27 N
Pretravel: PT	15±5°
Overtravel: OT min.	30°
Movement differential: MD max.	12°

Note: The operating characteristics for WLCA12 and WL01CA12 are measured at the lever length of 140 mm.

Operating characteristics	WLCA32-41 to 44, WL01CA32-41 to 44
Force necessary to reverse the direction of the lever: Max.	11.77 N
Movement until the lever reverses: Max.	50±5°
Movement until switch operation: Max.	55°
Movement after switch operation: Min.	35°

Note: 1. Plunger Models: For all models WL□ indicates a standard model and WL01□ indicates a microload model.
 2. Unless otherwise indicated, a tolerance of ±0.4 mm applies to all dimensions.

Top Plunger

WLD
 WL01D

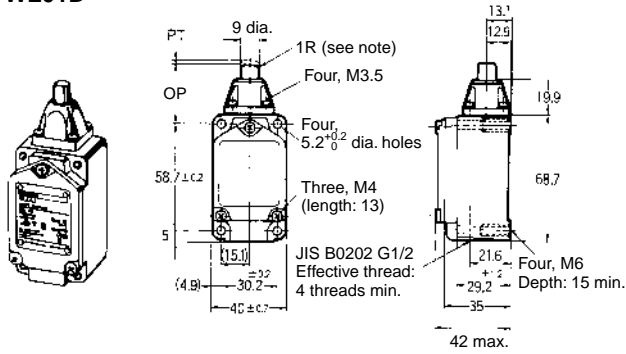

Note: Stainless steel plunger

Top-roller Plunger

WLD2
 WL01D2

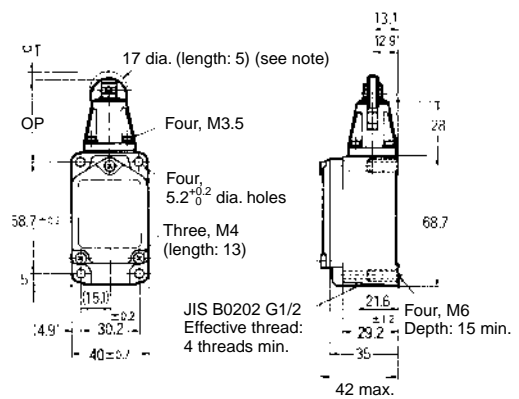

Note: Stainless sintered roller

Top-ball Plunger

WLD3
 WL01D3

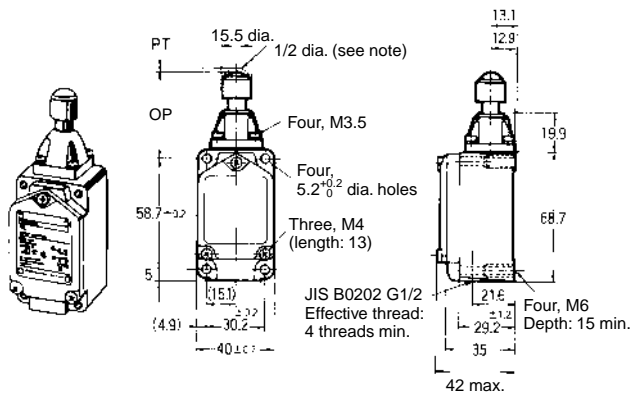

Note: Stainless steel ball

Sealed Top-roller Plunger

WLD28
 WL01D28

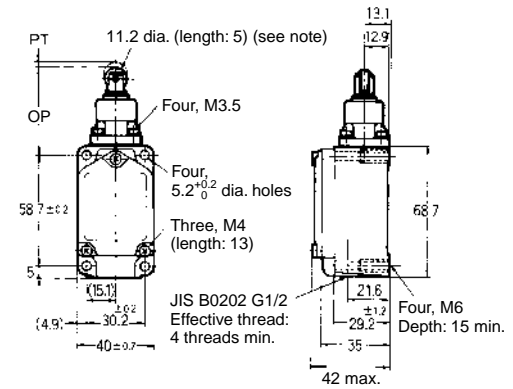

Note: Stainless steel roller

Note: Unless otherwise indicated, a tolerance of ±0.4 mm applies to all dimensions.

Horizontal Plunger

WLSD
WL01SD

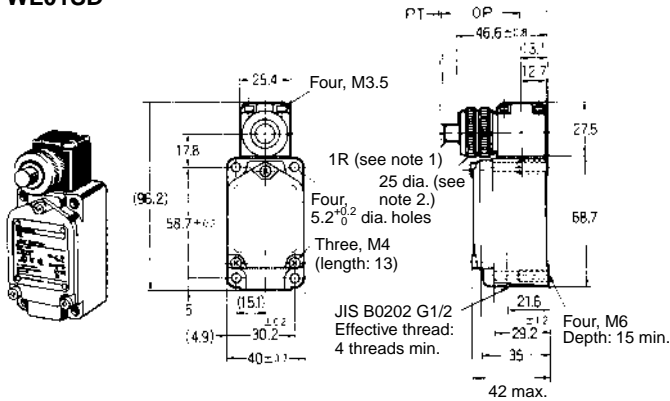

Note: 1. Stainless steel plunger
2. Cosmetic nuts.

Horizontal-roller Plunger

WLSD2
WL01SD2

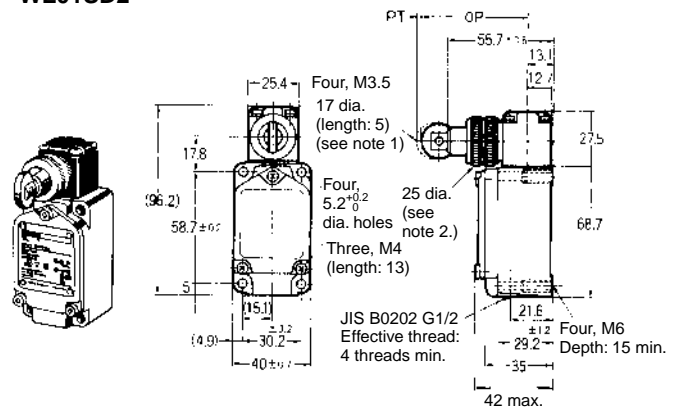

Note: 1. Stainless sintered roller
2. Cosmetic nuts
3. The WLSD21 model, which has the roller rotated by 90° is also available.

Horizontal-ball Plunger

WLSD3
WL01SD3

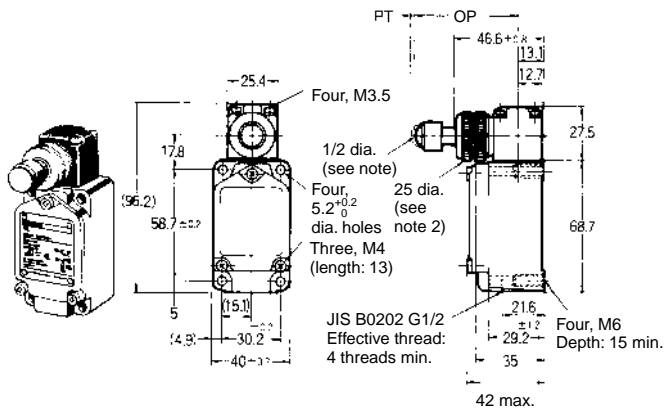

Note: 1. Stainless steel ball
2. Cosmetic nuts

Operating characteristics	WLD WL01D	WLD2 WL01D2	WLD3 WL01D3	WLD28 WL01D28	WLSD WL01SD	WLSD2 WL01SD2	WLSD3 WL01SD3
Operating force: OF max.	26.67 N	26.67 N	26.67 N	16.67 N	40.03 N	40.03 N	40.03 N
Release force: RF min.	8.92 N	8.92 N	8.92 N	4.41 N	8.89 N	8.89 N	8.89 N
Pretravel: PT max.	1.7 mm	1.7 mm	1.7 mm	1.7 mm	2.8 mm	2.8 mm	2.8 mm
Overtravel: OT min.	6.4 mm	5.6 mm	4 mm	5.6 mm	6.4 mm	5.6 mm	4 mm
Movement differential: MD max.	1 mm	1 mm	1 mm	1 mm	1 mm	1 mm	1 mm
Operating position: OP	34±0.8 mm	44±0.8 mm	44.5±0.8 mm	44±0.8 mm	40.6±0.8 mm	54.2±0.8 mm	54.1±0.8 mm
Total travel position: TTP max.	29.5 mm	39.5 mm	41 mm	39.5 mm	---	---	---

Note: 1. Flexible Rod Models: For all models WL□ indicates a standard model and WL01□ indicates a microload model.
 2. Unless otherwise indicated, a tolerance of ±0.4 mm applies to all dimensions.

Coil Spring

WLNJ
WL01NJ

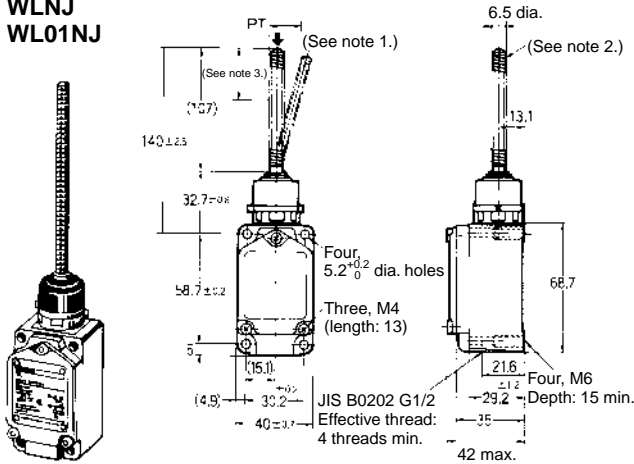

Note: 1. The coil spring may be operated from any direction except the axial direction (↓).
 2. Stainless steel coil spring
 3. Optimum operating range of the coil spring is within 1/3 of the entire length from the top end.

Coil Spring (Multi-wire)

WLNJ-30
WL01NJ-30

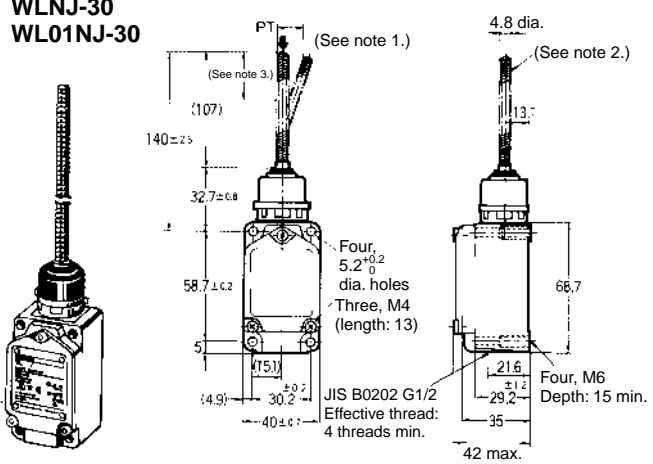

Note: 1. The coil spring may be operated from any direction except the axial direction (↓).
 2. Piano wire coil
 3. Optimum operating range of the coil spring is within 1/3 of the entire length from the top end.

Coil Spring (Resin Rod)

WLNJ-2
WL01NJ-2

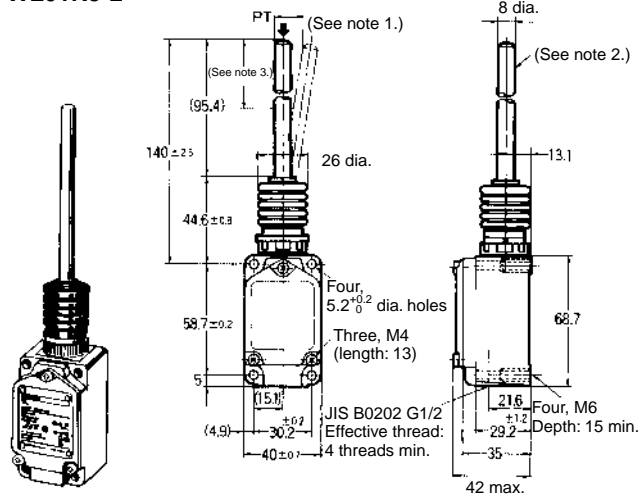

Note: 1. The coil spring may be operated from any direction except the axial direction (↓).
 2. Polyamide resin rod
 3. Optimum operating range of the rod is within 1/3 of the entire length from the top end.

Steel Wire

WLNJ-S2
WL01NJ-S2

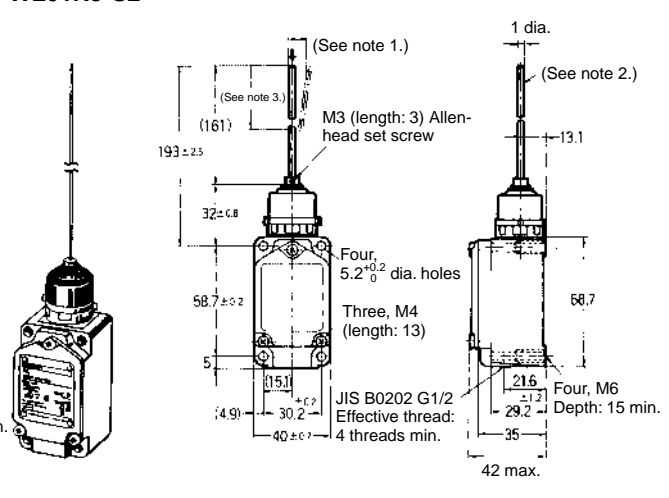

Note: 1. The coil spring may be operated from any direction except the axial direction (↓).
 2. Stainless steel wire
 3. Optimum operating range of the wire is within 1/3 of the entire length from the top end.

Operating characteristics	WLNJ WL01NJ (See note.)	WLNJ30 WL01NJ30 (See note.)	WLNJ-2 WL01NJ-2 (See note.)	WLNJ-S2 WL01NJ-S2 (See note.)
Operating force: OF max.	1.47 N	1.47 N	1.47 N	0.28 N
Pretravel: PT	20±10 mm	20±10 mm	40±20 mm	40±20 mm

Note: These values are taken from the top end of the wire or spring.

Overtravel Models

Overtravel models are Limit Switches which are provided with a greater OT to facilitate dog setting.

The overtravel models are classified into three types; general-purpose, high-sensitivity, and models which are capable of one-side 90° operation, the -2N Series.

The -2N Series can also be installed on either side.

Since this model is identical to the standard model in dimensions, both models are interchangeable.

Like the standard model, it is oil-tight, waterproof, and dustproof (complies with IP67).

General-purpose, high sensitivity models	Side-installation models
Head can be mounted in any of the four directions. The lever operates on either side at 80°.	The Head can be mounted in two directions, forward and backward. The lever operates on either side at 90°.
One-side operation is impossible.	One side operation is possible.

General-purpose/High Sensitivity Models

- Note:**
1. For all models WL□ indicates a standard model and WL01□ indicates a microload model.
 2. One-side operation is not possible with the general-purpose and high-sensitivity models.
 3. Unless otherwise indicated, a tolerance of ±0.4 mm applies to all dimensions.

Roller Lever

WLH2
WL01H2
WLG2
WL01G2

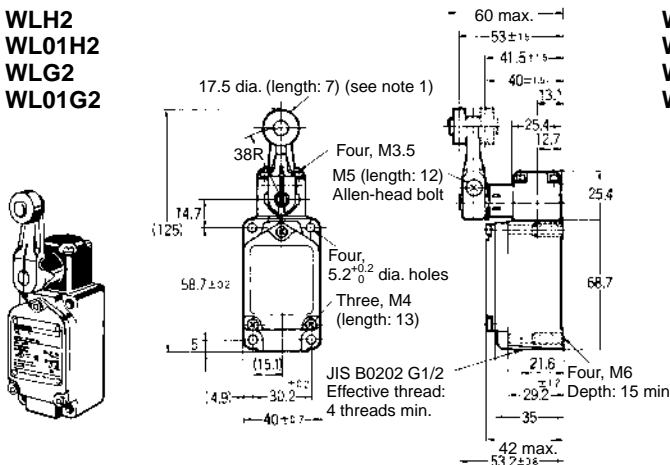

- Note:**
1. Stainless sintered roller
 2. WL□G2 is identical to other models except in the shape of the set position marker plate.
 3. The built-in switch for WLH2 is W-10FB3.
 4. The built-in switch for WLG2 is W-10FB3-8.

Adjustable Rod Lever

WLHL
WL01HL
WLGL
WL01GL

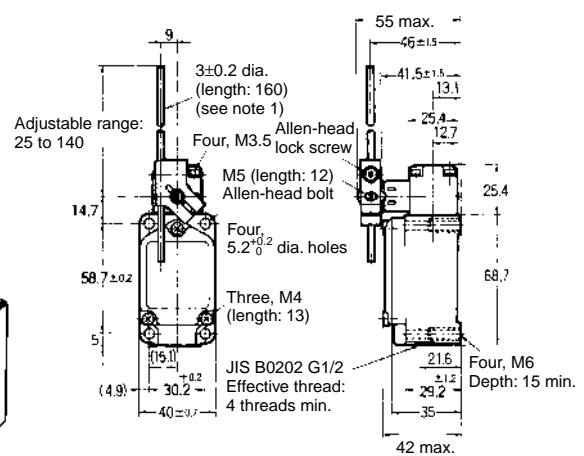

- Note:**
1. WL□GL is identical to other models except in the shape of the set position marker plate.
 2. The built-in switch for WLHL is W-10FB3.
 3. The built-in switch for WLGL is W-10FB3-8.

Adjustable Roller Lever

WLH12
 WL01H12
 WLG12
 WL01G12

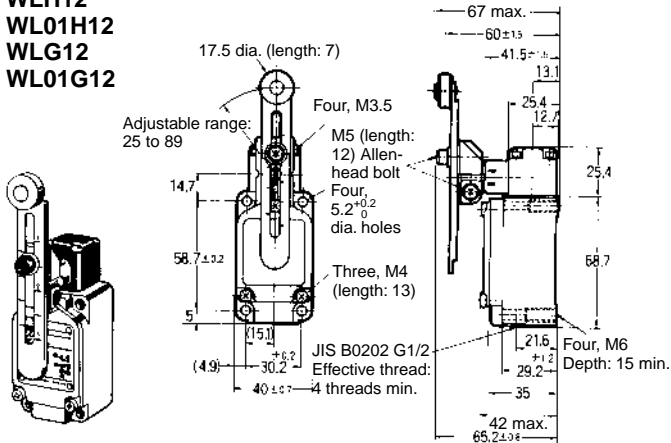

- Note:**
1. Stainless sintered roller
 2. WL□G12 is identical to other models except in the shape of the set position marker plate.
 3. The built-in switch for WLH12 is W-10FB3.
 4. The built-in switch for WLG12 is W-10FB3-8.

Operating characteristics	WLH2 WL01H2	WLG2 WL01G2	WLHL WL01HL (See note 2.)	WLGL WL01GL (See note 2.)	WLH12 WL01H12 (See note 1.)	WLG12 WL01G12 (See note 1.)
Operating force: OF max.	9.81 N	9.81 N	2.84 N	2.84 N	9.81 N	9.81 N
Release force: RF min.	0.98 N	0.98 N	0.25 N	0.25 N	0.98 N	0.98 N
Pretravel: PT	$15 \pm 5^\circ$	10^{+2}_{-1}	$15 \pm 5^\circ$	10^{+2}_{-1}	$15 \pm 5^\circ$	10^{+2}_{-1}
Overtravel: OT min.	55°	65°	55°	65°	55°	65°
Movement differential: MD max.	12°	7°	12°	7°	12°	7°

- Note:**
1. The operating characteristics of WLH12, WL01HL12, WLG12, and WL01G12 are measured at the lever length of 38 mm.
 2. The operating characteristics of WLHL, WL01HL, WLGL, and WL01GL are measured at the rod length of 140 mm.

OF and RF for WLH12 and WL01H12, with a lever length of 89 mm.

Operating characteristics	WLH12, WL01H12	WLG12, WL01G12
OF	4.18 N	4.18 N
RF	0.42 N	0.42 N

- Note:** 1. For all models WL□ indicates a standard model and WL01□ indicates a microload model.
 2. Unless otherwise indicated, a tolerance of ±0.4 mm applies to all dimensions.

Adjustable Rod Lever

WLHAL4
 WL01HAL4

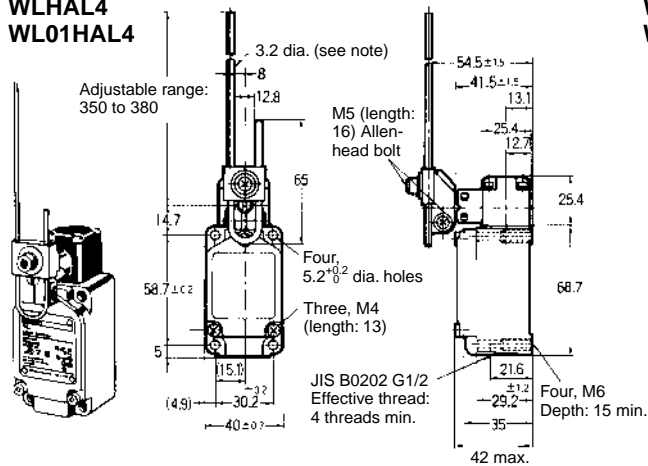

Note: Stainless steel rod

Rod Spring Lever

WLHAL5
 WL01HAL5

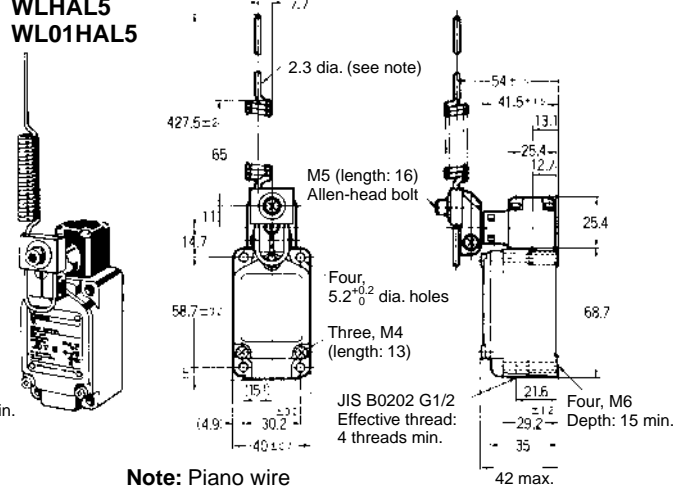

Note: Piano wire

Operating characteristics	WLHAL4 WL01HAL4 (See note 2.)	WLHAL5 WL01HAL5
Operating force: OF max.	0.98 N	0.90 N
Release force: RF min.	0.15 N	0.09 N
Pretravel: PT	15±5°	15±5°
Overtravel: OT min.	55°	55°
Movement differential: MD max.	12°	12°

Note: 1. With WLHAL4, WL01HAL4, WLHAL5, and WL01HAL5, the actuator's tare is large, so depending on the installation direction, they may not be properly reset. Always install so that the actuator is facing downwards.

2. The operating characteristics of WLHAL4, and WL01HAL4 are measured at the rod length of 380 mm.

Side-installation Models

90° operation on one side is possible by simply changing the direction of the cam.

- Note:** 1. For all models WL□ indicates a standard model and WL01□ indicates a microload model.
 2. With the side-installation models, 90° operation on one side is possible by simply changing the direction of the cam.
 3. Unless otherwise indicated, a tolerance of ±0.4 mm applies to all dimensions.

Roller Lever

WLCA2-2N
 WL01CA2-2N

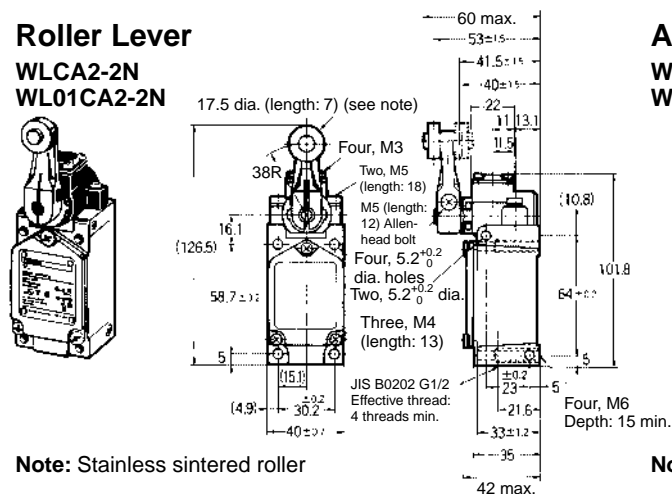

Note: Stainless sintered roller

Adjustable Roller Lever

WLCA12-2N
 WL01CA12-2N

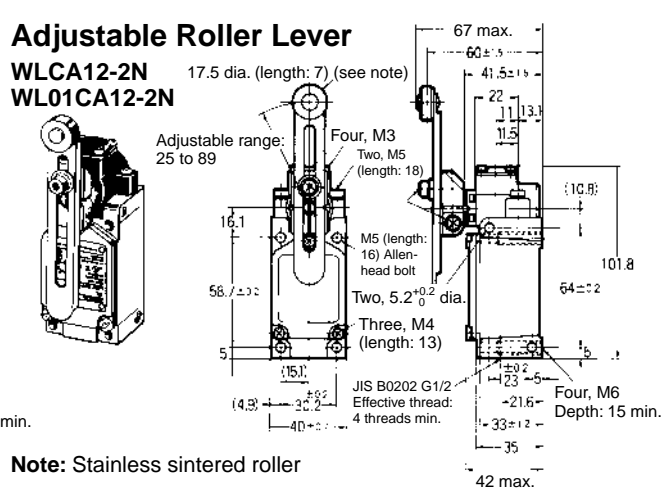

Note: Stainless sintered roller

Adjustable Rod Lever

WLCL-2N
WL01CL-2N

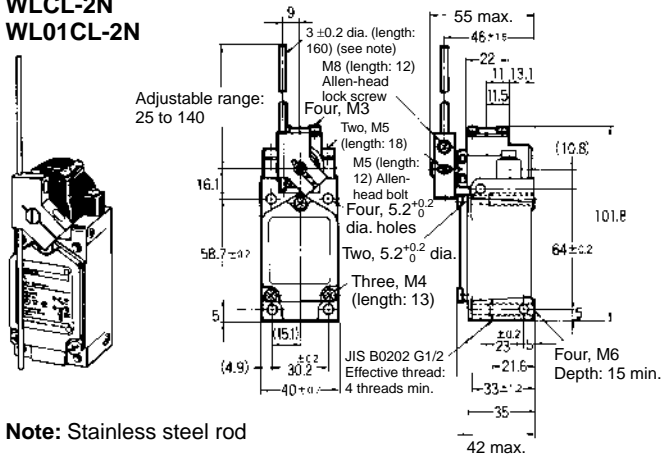

Note: Stainless steel rod

Operating characteristics	WLCA2-2N WL01CA2-2N	WLCA12-2N WL01CA12-2N (See note 1.)	WLCL-2N WL01CL-2N (See note 2.)
Operating force: OF max.	9.61 N	9.61 N	2.84 N
Release force: RF min.	1.18 N	1.18 N	0.25 N
Pretravel: PT max.	20°	20°	20°
Overtravel: OT min.	70°	70°	70°
Movement differential: MD max.	10°	10°	10°

Note: 1. The operating characteristics of WLCA12-2N and WL01CA12-2N are measured at the lever length of 38 mm.
2. The operating characteristics of WLCL-2N and WL01CL-2N are measured at the rod length of 140 mm.

OF and RF for WLCA12-2N and WL01CA12-2N, with a lever length of 89 mm.

Operating characteristics	WLCA12-2N, WL01CA12-2N
OF	4.10 N
RF	0.50 N

High-precision Models

The high-precision models feature a pretravel of 5° (as compared with 15° for the standard models) and a repeat accuracy twice as great as standard models. The high-precision models are ideal for positioning control of machine tools.

For all models WL□ indicates a standard model and WL01□ indicates a microload model.

Note: Unless otherwise indicated, a tolerance of ±0.4 mm applies to all dimensions.

Roller Lever

WLGCA2
WL01GCA2

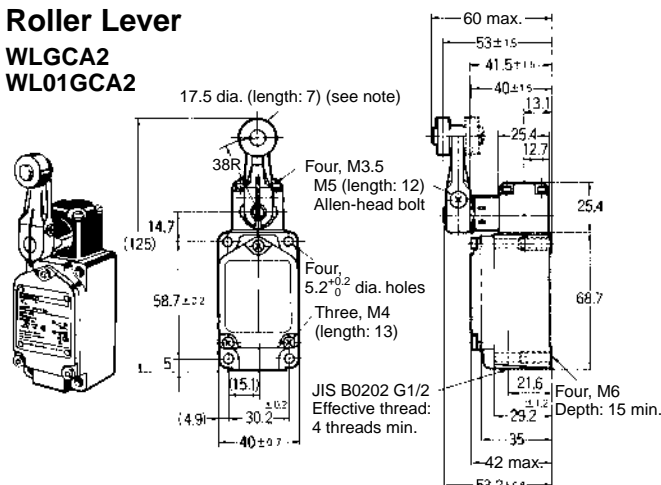

Note: Stainless sintered roller

Operating characteristics	WLGCA2 WL01GCA2
Operating force: OF max.	13.34 N
Release force: RF min.	1.47 N
Pretravel: PT	5 ⁺² ₀
Overtravel: OT min.	40°
Movement differential: MD max.	3°

Lamp-equipped Models

Roller Lever

WLCA2-LE/LD
WL01CA2-LE/LD

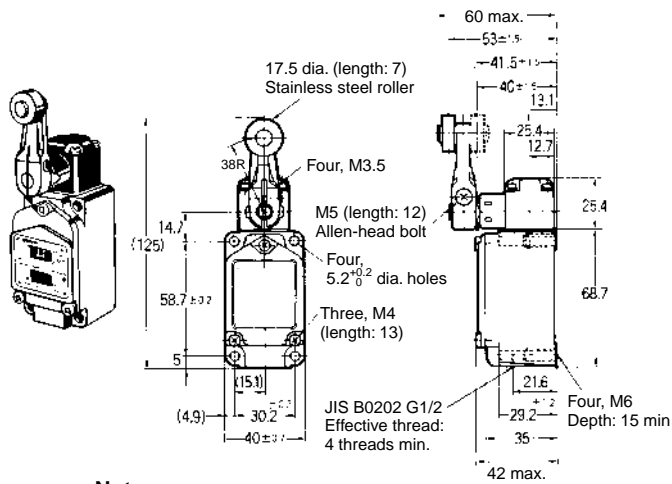

Note: Stainless steel roller

Note: Unless otherwise indicated, a tolerance of ± 0.4 mm applies to all dimensions.

OF max.	13.34 N
RF min.	2.23 N
PT	$15 \pm 5^\circ$
OT min.	30°
MD max.	12°

Sensor I/O Connector Models

Roller Lever Models

Standard Model (WLCA2), High-precision Model (WLGCA2), Overtravel Model (WLH2), and Overtravel High-sensitivity Model (WLG2)

- Note:
- For the WLG2 model, only the dimensions for the set position marker plate change.
 - Unless otherwise indicated, a tolerance of ± 0.4 mm applies to all dimensions.
 - The above diagram is for a lamp-equipped model.

Direct-wired Connector Models

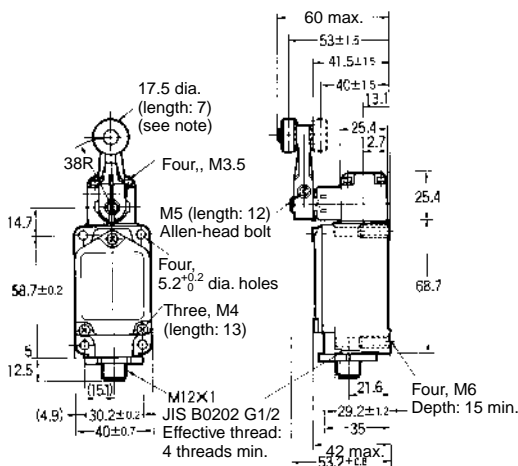

Note: Stainless sintered roller

Pre-wired Connector Models

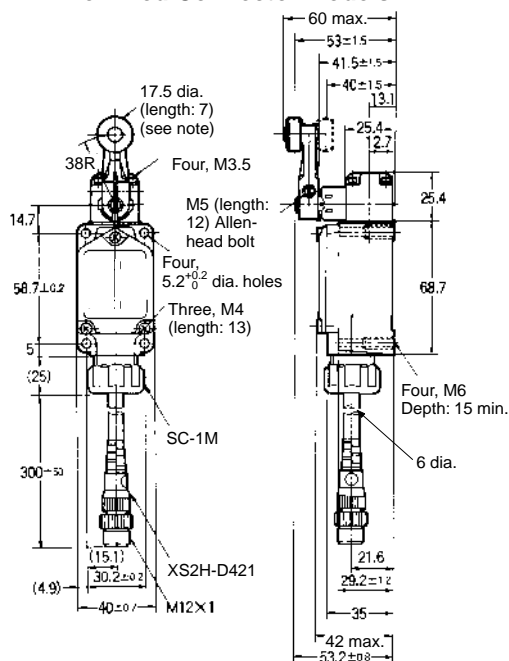

Note: Stainless sintered alloy roller

Operating characteristics	Roller lever/Standard model	Roller lever/High precision model	Roller lever/Overtravel model	Roller lever/Overtravel high sensitivity model
Operating force: OF max.	13.34 N	13.34 N	9.81 N	9.81 N
Release force: RF min.	2.23 N	1.47 N	0.98 N	0.98 N
Pretravel: PT	15±5°	5 ^{0+2°} _{-0°}	15±5°	10 ^{0+2°} _{-1°}
Overtravel: OT min.	30°	40°	55°	65°
Movement differential: MD max.	12°	3°	12°	7°

Top-roller Plunger

WLD2

- Note:** 1. Unless otherwise indicated, a tolerance of ±0.4 mm applies to all dimensions.
 2. The above diagram is for a lamp-equipped model.

Direct-wired Connector Models

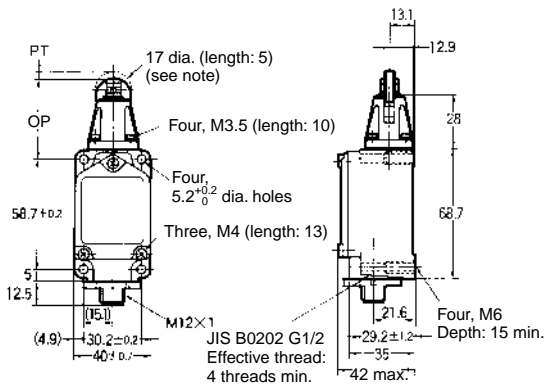

Note: Stainless sintered roller

Pre-wired Connector Models

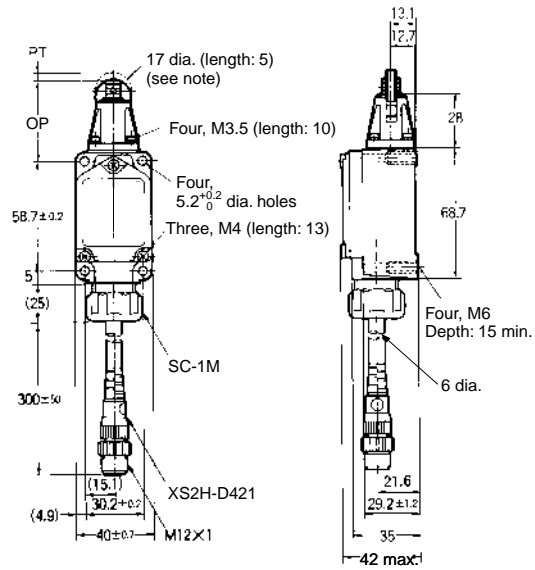

Note: Stainless sintered roller

Operating characteristics	Top-roller plunger actuator
Operating force: OF max.	26.67 N
Release force: RF min.	8.92 N
Pretravel: PT max.	1.7 mm
Overtravel: OT min.	5.6 mm
Movement differential: MD max.	1 mm
Operating position: OP	44±0.8 mm
Total travel position: TTP max.	39.5 mm

Sealed Top-roller Plunger

WLD28

- Note:** 1. Unless otherwise indicated, a tolerance of ± 0.4 mm applies to all dimensions.
 2. The above diagram is for a lamp-equipped model.

Direct-wired Connector Models

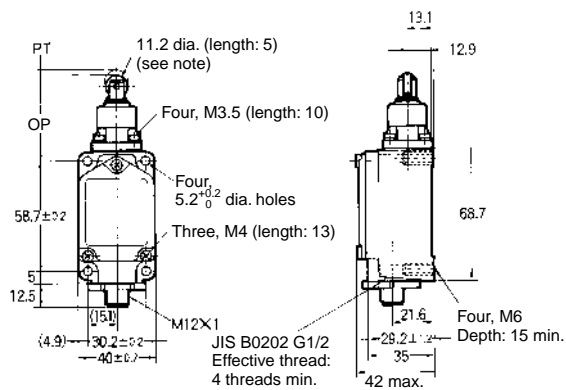

Note: Stainless sintered alloy roller

Pre-wired Connector Models

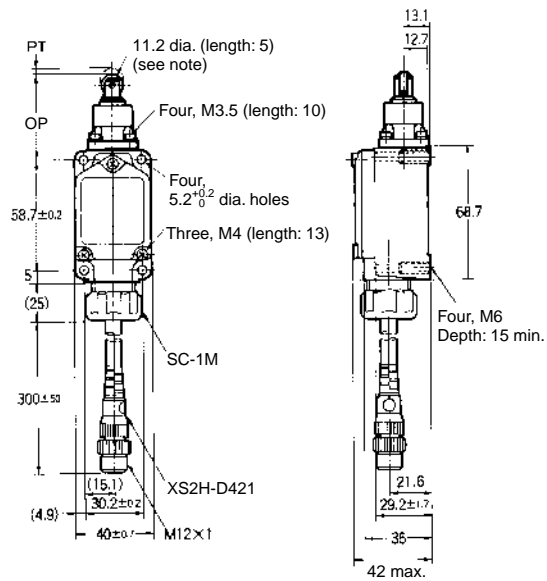

Note: Stainless sintered alloy roller

Operating characteristics	Sealed top-roller plunger actuator
Operating force: OF max.	16.67 N
Release force: RF min.	4.41 N
Pretravel: PT max.	1.7 mm
Overtravel: OT min.	5.6 mm
Movement differential: MD max.	1 mm
Operating position: OP	44 ± 0.8 mm
Total travel position: TTP max.	39.5 mm

■ Environment-resistant Models

The dimensions and operating characteristics are the same as general-purpose, environment-resistant models.

■ Spatter-prevention Models

Roller Lever (Screw Terminals)

WLCA2-□S/WL01□-□S
 WLH2-□S/WLG2-□S
 WLGA2-□S

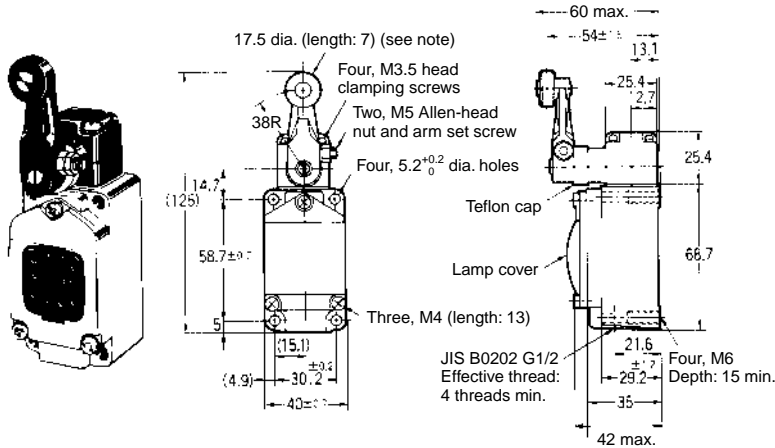

Note: Stainless steel roller

Roller Lever (Pre-wired Connector)

WLCA2-□S-M1J/WL01□-□S-M1J
 WLH2-□S-M1J/WLG2-□S-M1J
 WLGA2-□S-M1J

Note: The dimensions are the same regardless of the number of core lines.

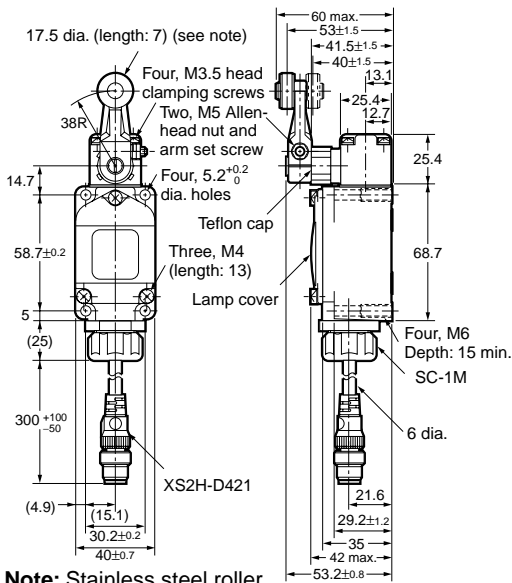

Note: Stainless steel roller

Operating characteristics	Standard	Overtravel models		High-precision
		General	High-sensitivity	
Operating force: OF max.	13.34 N	9.81 N	9.81 N	13.34 N
Release force: RF min.	2.23 N	0.98 N	0.98 N	1.47 N
Pretravel: PT	15°±5°	15°±5°	10° ⁺² ₋₁	5° ⁺² ₋₀
Overtravel: OT min.	30°	55°	65°	40°
Movement differential: MD max.	12°	12°	7°	3°

Sealed Top-roller Plunger (Screw Terminals)

WLD28-□S

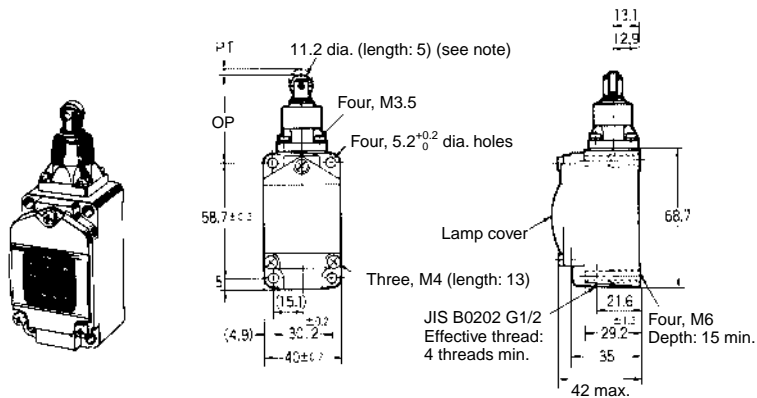

Note: Stainless steel roller

Sealed Top-roller Plunger (Pre-wired Connector)

WLD28-□S-M1J

Note: The dimensions are the same regardless of the number of core lines.

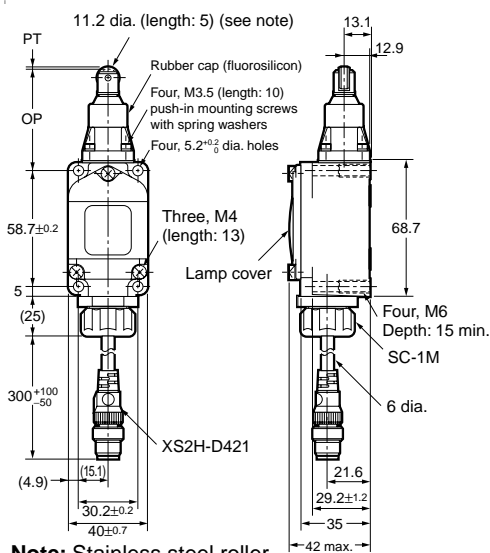

Note: Stainless steel roller

Operating characteristics	WLD28-L□S
Operating force: OF max.	16.67 N
Release force: RF min.	4.41 N
Pretravel: PT max.	1.7 mm
Overtravel: OT min.	5.6 mm
Movement differential: MD max.	1 mm
Operating position: OP	44±0.8 mm
Total travel position: TTP max.	39.5 mm

Note: Unless otherwise indicated, a tolerance of ±0.4 mm applies to all dimensions.

■ Actuators (Levers Only)

Note: 1. Lever: Only rotating lever models are illustrated.

2. Unless otherwise indicated, a tolerance of ± 0.4 mm applies to all dimensions.

3. When using the adjustable roller (rod) lever, make sure that the lever is facing downwards. Use caution, as telegraphing (the Switch turns ON and OFF repeatedly due to inertia) may occur.

WL-1A100

Standard Lever

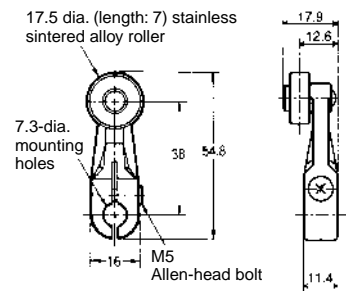

WL-1A115

Resin Roller

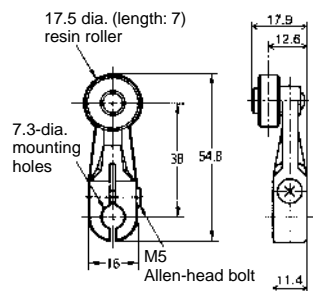

WL-1A400

Bearing Roller

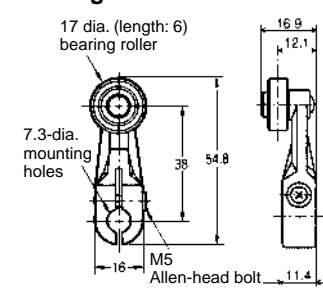

WL-1A118

Nylon Roller: Roller Width: 30 mm

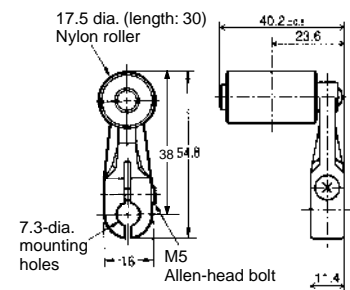

WL-1A105

Double Nut

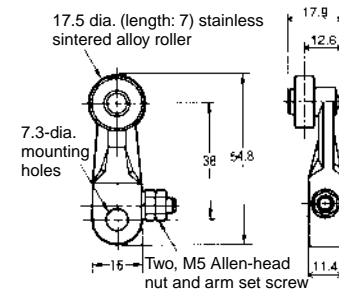

WL-1A103S

Spatter Prevention

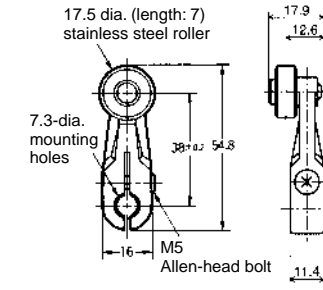

WL-1A200

Lever Length: 50 Roller Width: 15

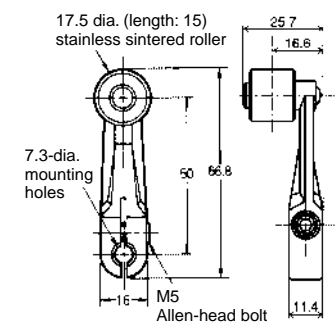

WL-1A300

Lever Length: 63

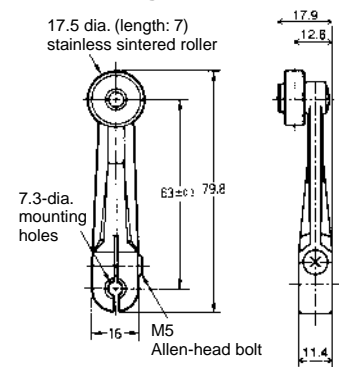

WL-2A100

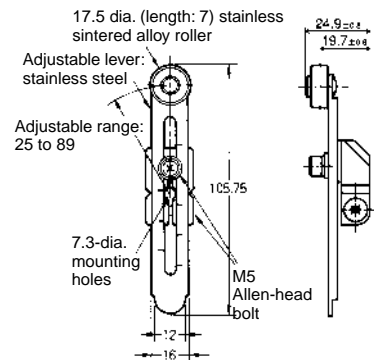

**WL-2A111
Resin Roller**

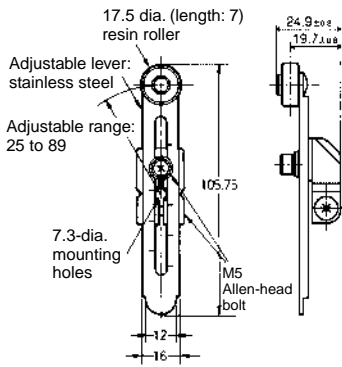

**WL-2A107
Double Nut**

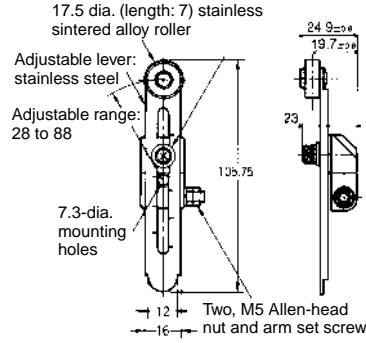

**WL-2A108
Resin Roller**

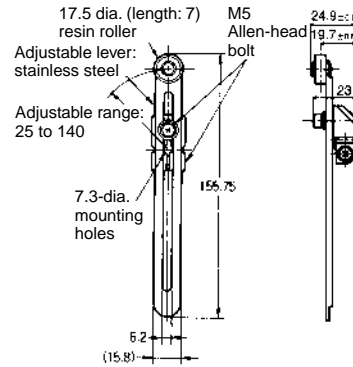

WL-2A122

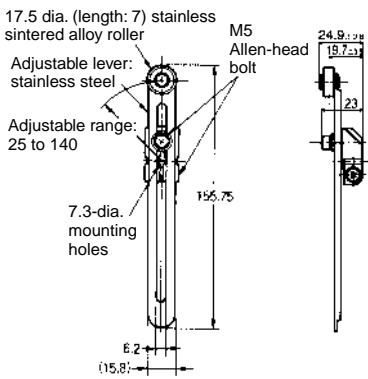

WL-2A106

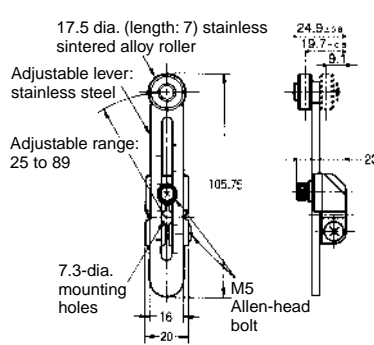

WL-2A130

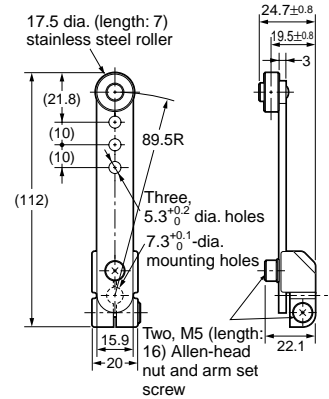

Note: Can be installed on the rear side.

WL-2A104

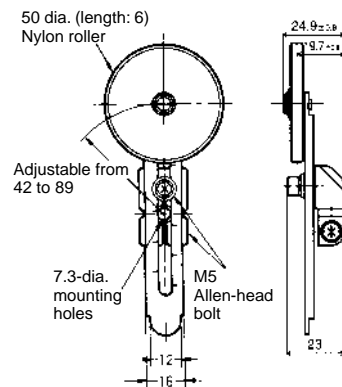

WL-2A110

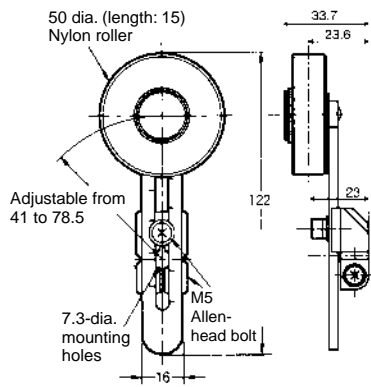

WL-2A105

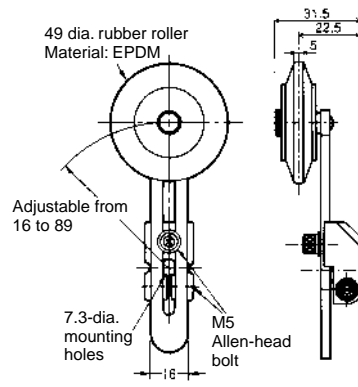

WL-1A106

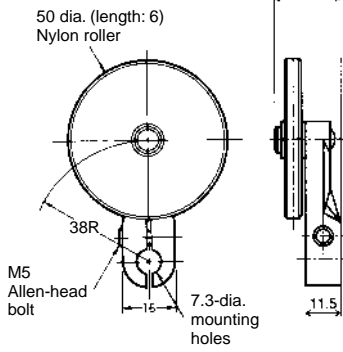

WL-1A110

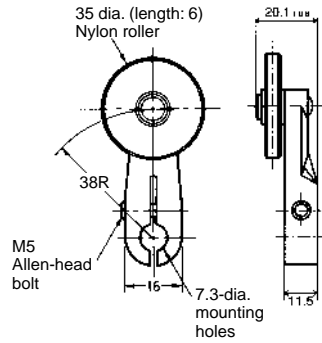

WL-4A100

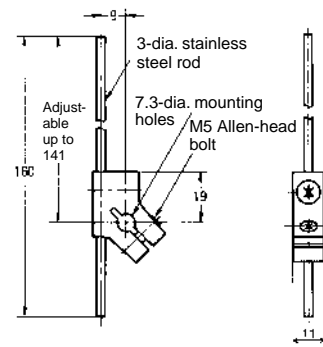

WL-4A201

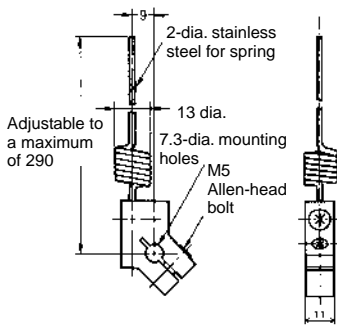

WL-3A100

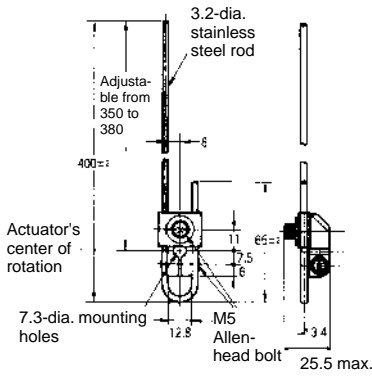

**WL-3A106
Double Nut**

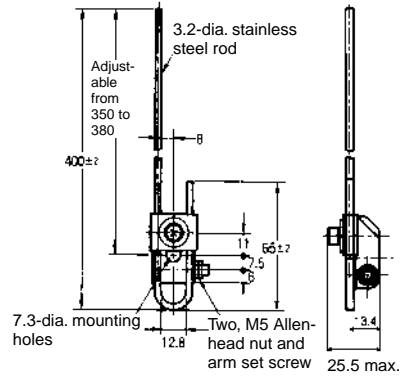

WL-3A108

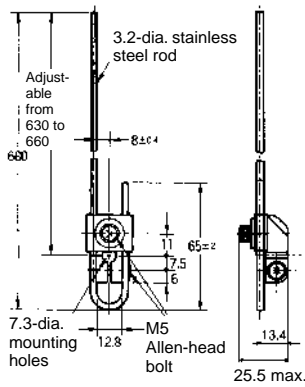

WL-3A200

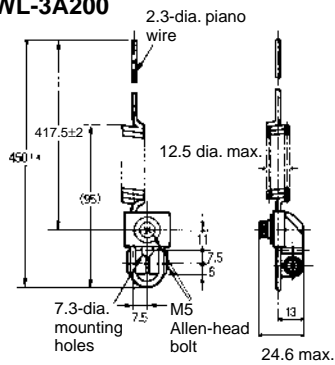

WL-3A203

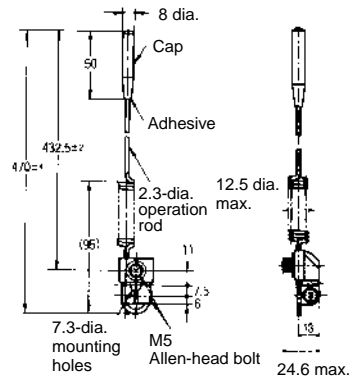

WL-4A112

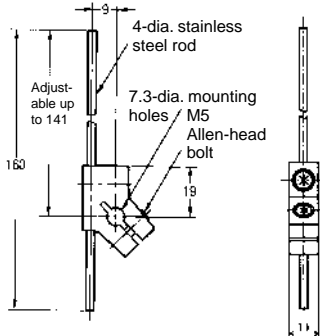

WL-2A129

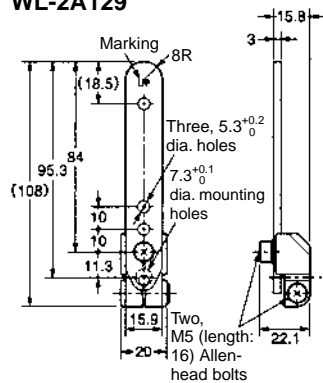

WL-5A101

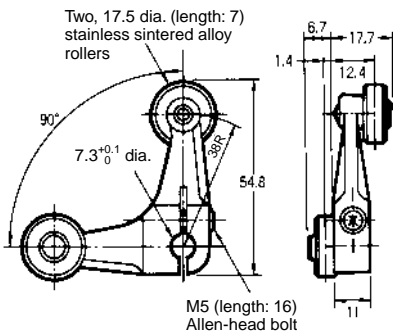

WL-5A100 has a resin roller

WL-5A103

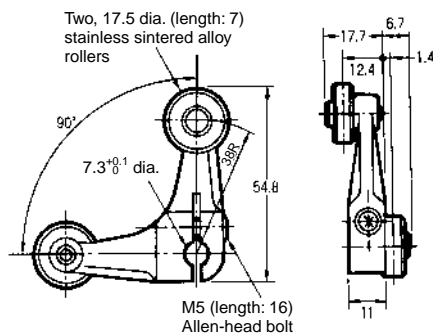

WL-5A102 has a resin roller

WL-5A105

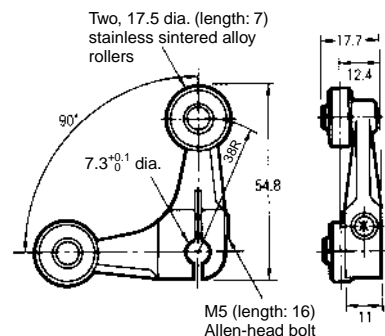





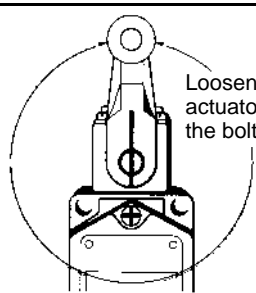
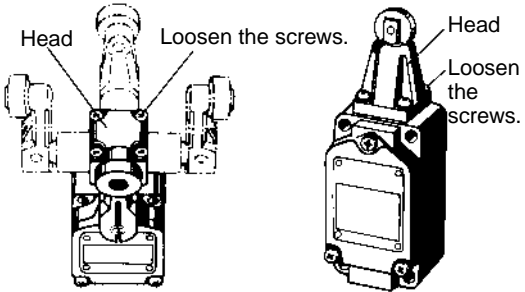

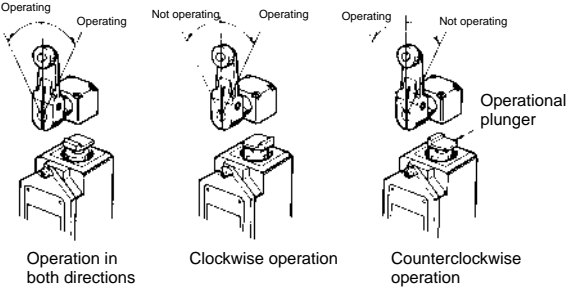
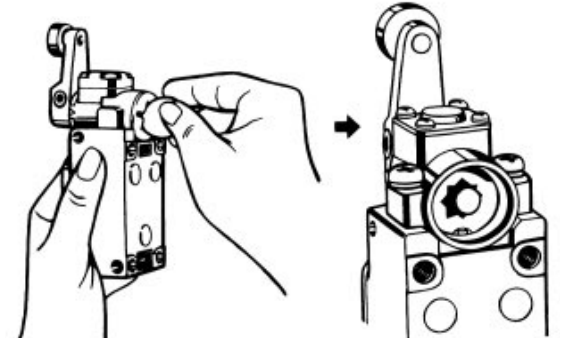
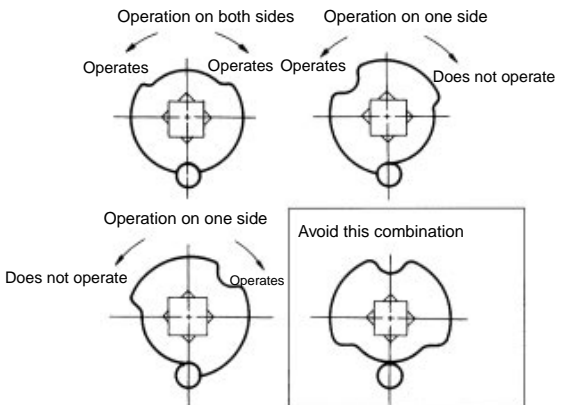
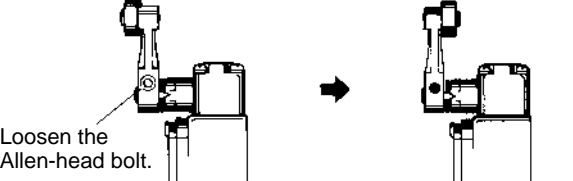
WL-5A104 has a resin roller

Installation

Item	Appropriate model/actuator	Details
<p>Changing the installation position of the actuator</p> <p>By loosening the Allen-head bolt on the actuator lever, the position of the actuator can be set anywhere within the 360°. With Lamp-equipped Switches, the actuator lever comes in contact with the top of the lamp cover, so use caution when rotating and setting the lever. When the lever only moves forwards and backwards, it will not contact the lamp cover.</p>	<p>Roller Levers: WLCA2, WL01CA2, WLH2, WL01H2, WLG2, WL01G2</p> <p>Adjustable Roller Levers: WLCA12, WL01CA12, WLH12, WL01H12, WLG12, WL01G12</p> <p>Adjustable Rod Levers: WLCL, WL01CL, WLHL, WL01HL, WLGL, WL01GL</p>	 <p>Loosen the M5 x 12 bolt, set the actuator's position and then tighten the bolt again.</p>
<p>Changing the orientation of the Head</p> <p>By removing the screws in the four corners of the Head, the Head can be set in any of the four directions. Be sure to change the plunger for internal operations at the same time. (The operational plunger does not need to be changed on overtravel general-purpose and high-sensitivity models.) The roller plunger can be set in either two positions at 90°. WLCA2-2N and WL01CA2-2N can only be set in either the forward or backward direction.</p>	<p>Roller Levers: WLCA□, WL01CA□, WLGCA□</p> <p>Adjustable Rod Levers: WLCL, WL01CL</p> <p>Horizontal Plungers: WLSD□, WL01SD□</p> <p>Roller Plungers: WLD2, WL01D2</p> <p>Sealed Roller Plungers: WLD28, WL01D28.</p> <p>Note: Does not include -RP60 Series or -141 Series.</p>	 <p>Head</p> <p>Loosen the screws.</p> <p>Head</p> <p>Loosen the screws.</p>

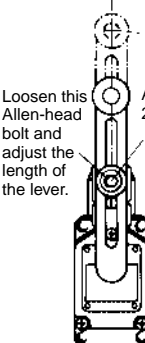
Item	Appropriate model/actuator	Details
<p>Changing the operating direction By removing the Head on models which can operate on one-side only, and then changing the direction of the operational plunger, one of three operating directions can be selected. In the case of overtravel models, by loosening the rubber holder using either a coin or a flat-blade screwdriver, and changing the direction of the internal rubber section, one of three operating directions can be selected.</p> <p>The tightening torque for the screws on the Head is 0.78 to 0.88 N·m.</p>	<p>Roller Levers: WLCA2, WL01CA2, WLGCA2, WLMGCA2□ Adjustable Roller Levers: WLCA12, WL01CA12 Adjustable Rod Levers: WLCL, WL01CL Overtravel Models: WLCA□-2N, WL01CA□-2N</p> <p>Note: The diagram at the right is not correct for the overtravel -2N models.</p>	<p>The output of the Switch will be changed, regardless of which direction the lever is pushed. The output of the Switch will only be changed when the lever is pushed in one direction.</p>  <p>For details on overtravel -2N models, refer to page 28.</p> <p>Cam direction changing procedure for side-installation models</p> <p>Loosen the cam holder with a coin or screwdriver. Take out the cam from the Switch. Change the direction of the cam as required by your intended operation and then reinstall the cam.</p>  <p>Relationship of cam to operation as observed from the rear of Switch</p> 
<p>Installing the roller on the inside By installing the roller lever in the opposite direction, the roller can be installed on the inside. (Set so that operation can be completed within a 180° level range.)</p>	<p>Roller Levers: WLCA□, WL01CA□, except for the adjustable roller levers. Fork Lever Locks: WLCA32-4□, WL01CA32-4□</p>	 <p>Loosen the Allen-head bolt.</p>

Item	Appropriate model/actuator	Details
<p>Selecting the roller position There are four types of fork lever lock for use depending on the roller position.</p>	<p>Fork Lever Locks: WLCA32-4□, WL01CA32-4□</p>	<div style="display: flex; justify-content: space-around;"> <div style="text-align: center;"> <p>WLCA32-41</p>  </div> <div style="text-align: center;"> <p>WLCA32-43</p>  </div> </div> <div style="display: flex; justify-content: space-around; margin-top: 10px;"> <div style="text-align: center;"> <p>WLCA32-42</p>  </div> <div style="text-align: center;"> <p>WLCA32-44</p>  </div> </div> <p>Note: An explanation of the operation of fork lever locks is provided after this table.</p>
<p>Adjusting the length of the rod or lever The length of the rod or lever can be adjusted by loosening the Allen-head bolt.</p>	<p>Adjustable Roller Levers: WLCA12, WL01CA12 etc. Adjustable Rod Levers: WLCL, WL01CL, etc.</p>	<p>WLCA12 etc.</p> <div style="display: flex; justify-content: space-around;"> <div style="text-align: center;">  <p>Loosen this Allen-head bolt and adjust the length of the lever.</p> <p>Adjustment range: 25 to 89 mm</p> </div> <div style="text-align: center;">  <p>Loosen this Allen-head bolt and adjust the length of the rod.</p> </div> </div>

■ Operation of Fork Lever Locks

The fork lever lock is configured so that the dog pushes the lever to reverse the output and this reversed state is maintained even after the dog continues on. If the dog then pushes the lever from the opposite direction, the lever will return to its original position.

Example



Precautions

Refer to the *Technical Information for Limit Switches* (Cat. No. C121).

Correct Use

When a rod or wired-type actuator is used, do not touch the top end of the actuator. Doing so may result in injury.

Applicable models: WLHAL5 and WL01HAL5 Rod Spring Levers and WLNJ-S2 and WL01NJ-S2 Steel-wire Actuators.

A short-circuit may cause damage to the Switch, so insert a circuit breaker fuse, of 1.5 to 2 times the rated current, in parallel with the Switch. In order to meet EN approval ratings, use a 10-A fuse that corresponds to IEC269, either a gI or gG for general-purpose types and spatter-prevention models only.

When wiring terminal screws, use M4 round crimp terminals and tighten screws to the recommended torque. Wiring with broken wires, or the incorrect crimp terminals, or not tightening screws to the recommended torque can lead to short-circuits, leakage current, and fire.

When performing internal wiring there is a chance of short-circuit, leakage current, or fire, so be sure to protect the inside of the Switch from splashes of oil or water, corrosive gases, and cutting powder.

Using an inappropriate connector or assembling Switches incorrectly (assembly, tightening torque) can result in malfunction, leakage current, or fire, so be sure to read the instruction manual thoroughly beforehand.

Even when the connector is assembled and set correctly, the end of the cable and the inside of the Switch may come in contact. This can lead to malfunction, leakage current, or fire, so be sure to protect the end of the cable from splashes of oil or water and corrosive gases.

Environmental Precautions

When the Switch is used in locations subject to splashes of water or oil, the material of the seal, which ensures the sealing properties of the Switch, may undergo changes in shape and quality. This is due to deterioration (including expansion and contraction), and may result in reduced performance, ineffective return, and ineffective sealing (leading to ineffective contact, insulation, leakage current, and fire). Confirm the possible effects of the operating environment on the Switch before use.

Built-in Switch

Do not remove or replace the built-in switch. If the position of the built-in switch moves, it can cause reduced performance, and if the insulation sheet moves (separator), the insulation may become ineffective.

Tightening Torque

If screws are too loose they can lead to an early malfunction of the Switch, so ensure that all screws are tightened using the correct torque.

No.	Type	Torque
①	Head mounting screw	0.78 to 0.88 N·m
②	Cover mounting screw	1.18 to 1.37 N·m
③	Allen-head bolt (for securing the lever)	4.90 to 5.88 N·m
④	Terminal screw	0.59 to 0.78 N·m
⑤	Connector	1.77 to 2.16 N·m
⑥	Main Unit screws	4.90 to 5.88 N·m

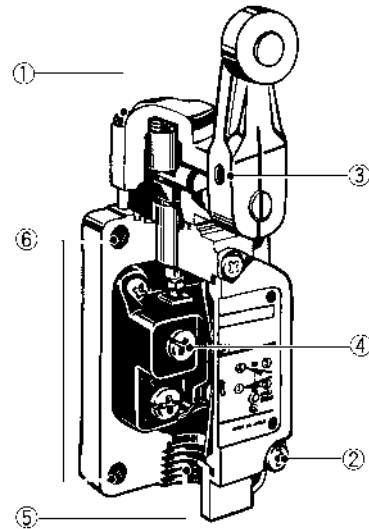

In particular, when changing the direction of the Head, make sure that all screws are tightened again to the correct torque. Do not allow foreign objects to fall into the Switch.

Installing the Switch

To install the Switch, make a mounting panel, as shown in the following diagram, and tighten screws using the correct torque.

Standard/Overtravel model	Overtravel model (side installation)
<p>Mounting holes</p> <p>Four, $5.2^{+0.2}_0$ dia. holes</p>	<p>Mounting holes</p> <p>Two, $5.2^{+0.2}_0$ dia. holes</p>

Connectors

Either the easy-to-use Allen-head nut or the SC Connector can be used as connectors. To ensure high-sealing properties, use the SC Connector. Consult your OMRON representative for details on SC Connectors.

Wiring

Use 1.25-mm lead wires and M4-insulation covered crimp terminals for wiring.

Crimp Terminal External Dimensions

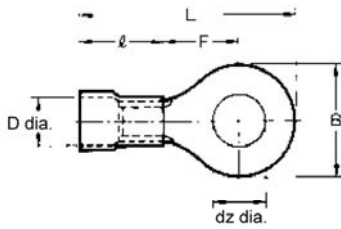

dz dia.:	4.3
D dia.:	4.5
B:	8.5
L:	21.0
F:	7.8
ℓ:	9.0 (mm)

Wiring Method

Switch Box Section

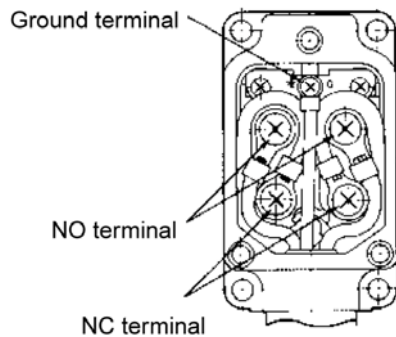

Note: The ground terminal is only installed on models with ground terminals.

Rotating Lever Set Position

All rotating lever models, except the fork lever lock, have a set position marker plate. (See page 109.) After operation, set the indicator needle on the marker plate so that is in the convex section of the bearing.

Terminal Plate

By using a short circuit plate, as shown in the following diagram, the Switch can be fabricated into a single-polarity double-break model. When ordering specify WL Terminal Plate (product code: WL-9662F).

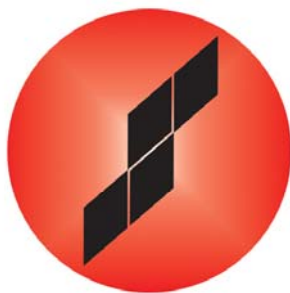
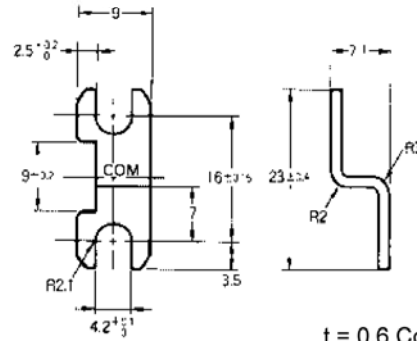

THEGIOIDIEN

ALL DIMENSIONS SHOWN ARE IN MILLIMETERS.

To convert millimeters into inches, multiply by 0.03937. To convert grams into ounces, multiply by 0.03527.